

HRT/6-500/25 BPN

IP54



Dimensiones y conexiones Dimensions and wiring

Características Characteristics

Tensión Voltage	3 ~ 400V 50Hz	
Tipo motor Motor type	6 polos 6 poles	IP54 cl.F
Potencia absorbida máxima Maximum power absorbed	0,23 kW	
Intensidad absorbida máxima Maximum absorbed current	0,5 A	
Condensador Capacitor		
Ia/In Is/In	2,6	
Temperatura del aire Air temperature	-40°C < T < +70°C	
Peso Weight	11,0 kg	
Código ventilador Fan code number	5700206500	
Código motor Motor code number	0342759008	

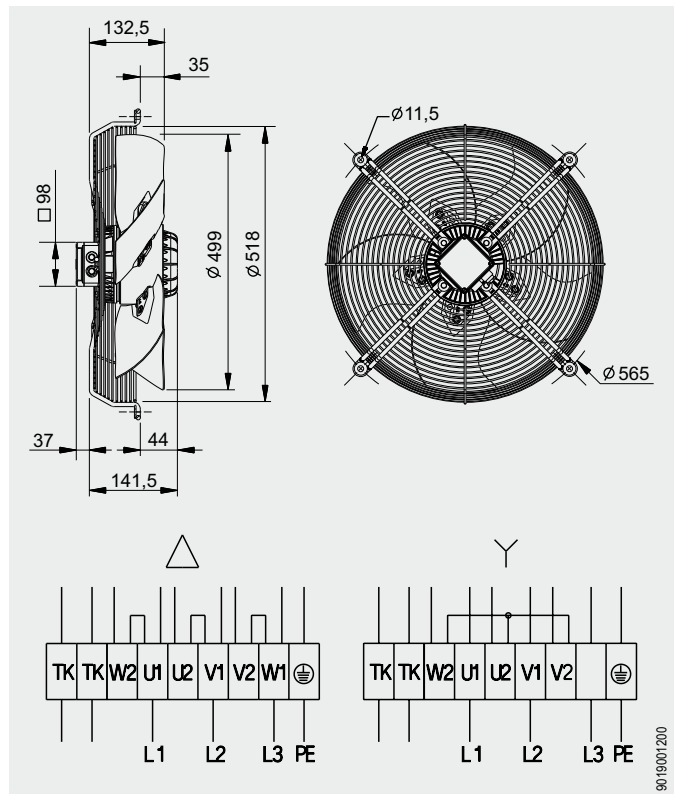

Curvas características / Performance curves (17/04/2012)

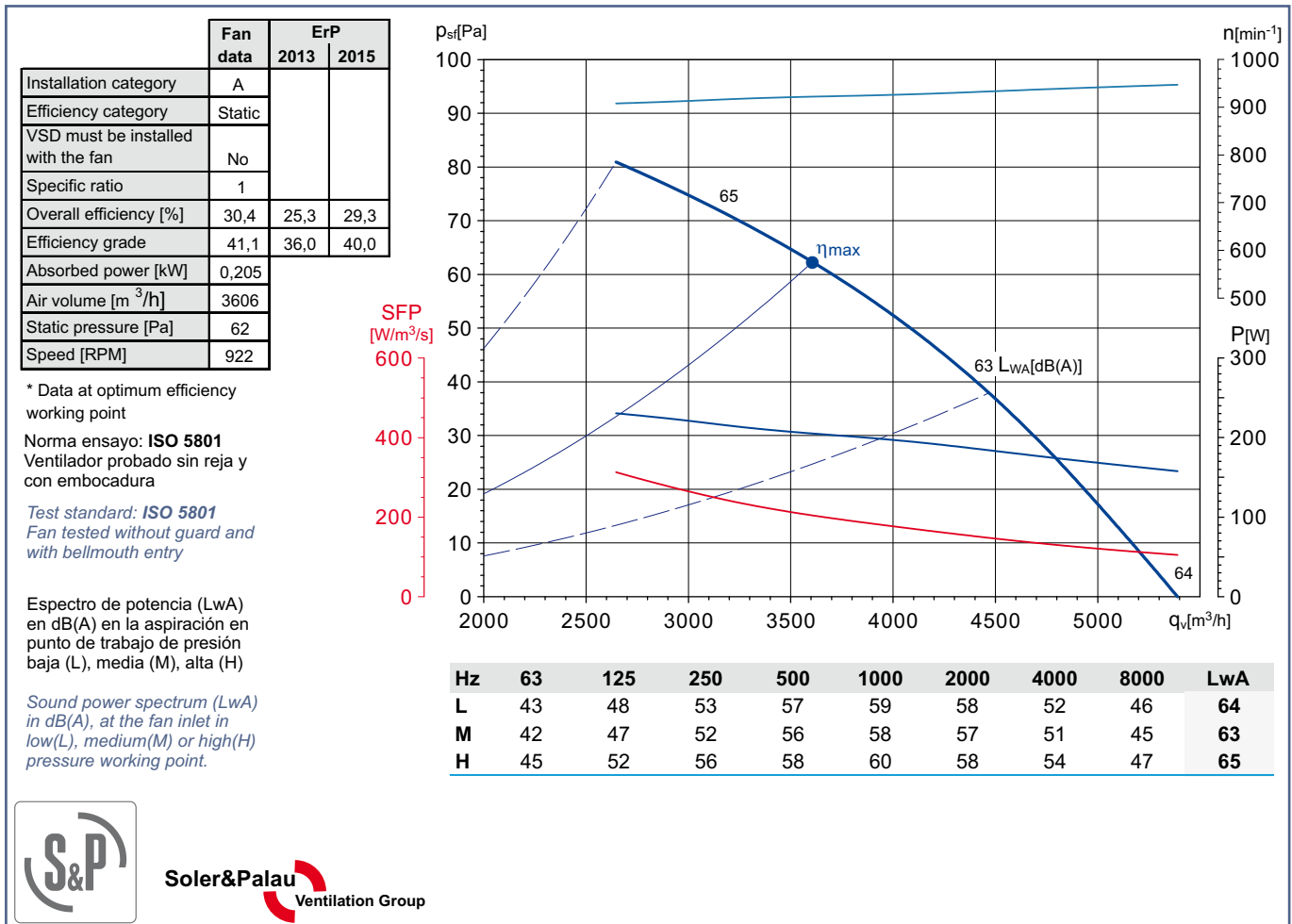

Soler&Palau
Ventilation Group