

HRT/4-560/30 BPN

IP54



Dimensiones y conexiones

Dimensions and wiring

Características

Characteristics

| | | |
|-----------------------------------------------------------------------|--------------------|-----------|
| Tensión Voltage | 3 ~ 400V 50Hz | |
| Tipo motor Motor type | 4 polos 4 poles | IP54 cl.F |
| Potencia absorbida máxima Maximum power absorbed | 1,28/0,90 kW | |
| Intensidad absorbida máxima Maximum absorbed current | 2,4/1,5 A | |
| Condensador Capacitor | | |
| Ia/In Is/In | 2,9 | |
| Temperatura del aire Air temperature | -40°C < T < +70°C | |
| Peso Weight | 18,5 kg | |
| Código ventilador Fan code number | 5700294100 | |
| Código motor Motor code number | 0343652004 | |

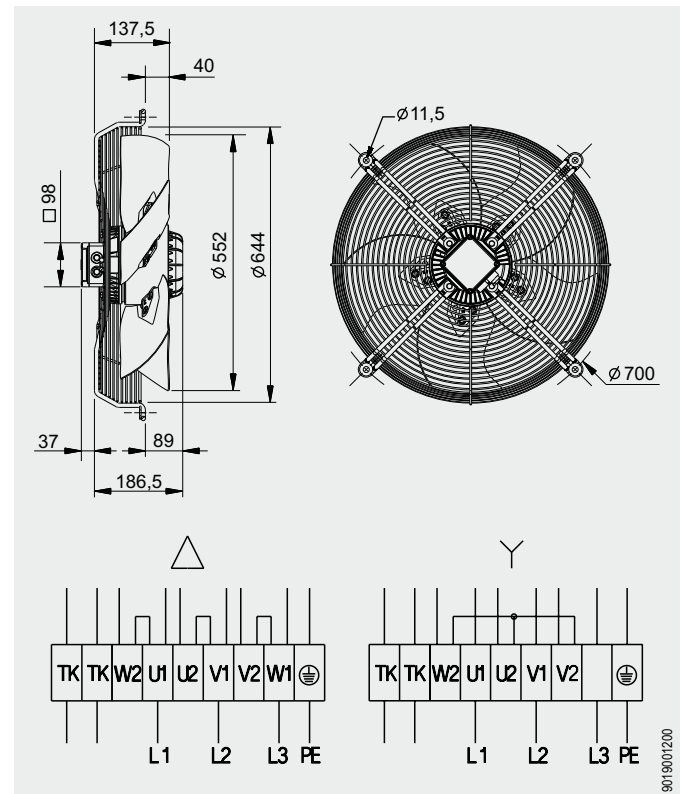

Curvas características / Performance curves (23/04/2012)

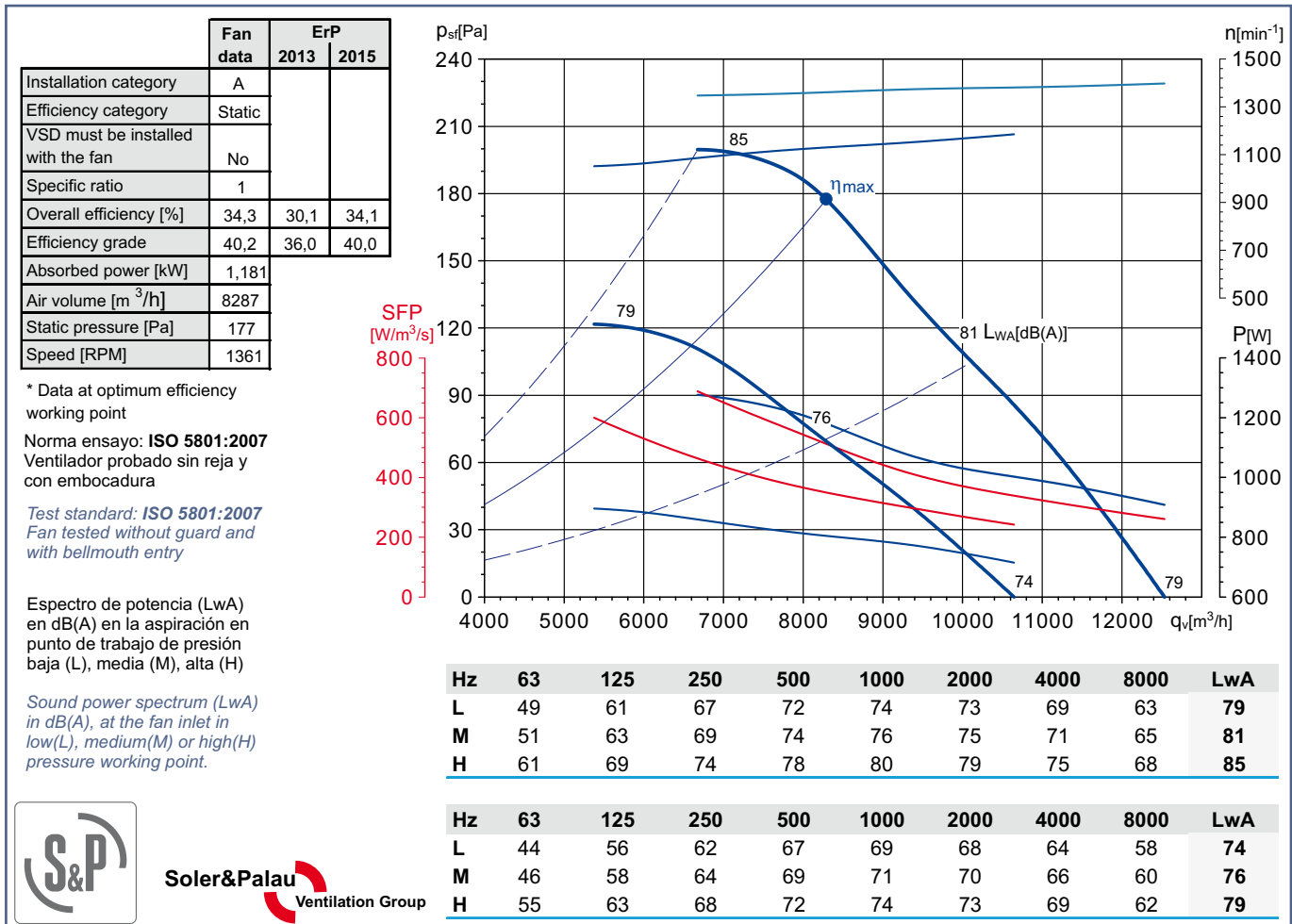

Soler&Palau
Ventilation Group