

HRST/4-630/33 BZ

IP54



Dimensiones y conexiones

Dimensions and wiring

Características

Characteristics

Tensión Voltage	3 ~ 400V 50Hz	
Tipo motor Motor type	4 polos <i>4 poles</i>	IP54 cI.F
Potencia absorbida máxima Maximum power absorbed	2,55 kW	
Intensidad absorbida máxima Maximum absorbed current	4,7 A	
Condensador Capacitor		
Ia/In Is/In	2,7	
Temperatura del aire Air temperature	-40°C < T < +50°C	
Peso Weight	45,0 kg	
Código ventilador Fan code number	5720058000	
Código motor Motor code number	9024000000	

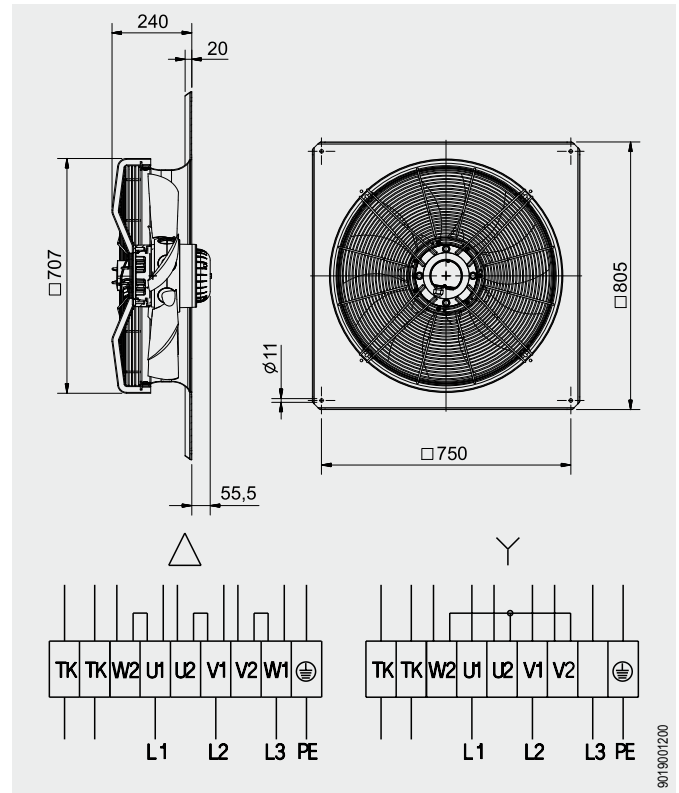

Curvas características / Performance curves (23/03/2011)

	Fan data	ErP	
		2013	2015
Installation category	A		
Efficiency category	Static		
VSD must be installed with the fan	No		
Specific ratio	1		
Overall efficiency [%]	32,3	32,1	36,1
Efficiency grade	36,2	36,0	40,0
Absorbed power [kW]	2,443		
Air volume [m ³ /h]	12260		
Static pressure [Pa]	232		
Speed [RPM]	1312		

* Data at optimum efficiency working point

Norma ensayo: **ISO 5801**
Ventilador probado sin rejilla con embocadura

Test standard: **ISO 5801**
Fan tested without guard and with bellmouth entry

Espectro de potencia (LWA) en dB(A) en la aspiración en punto de trabajo de presión baja (L), media (M), alta (H)

Sound power spectrum (LWA) in dB(A), at the fan inlet in low(L), medium(M) or high(H) pressure working point.

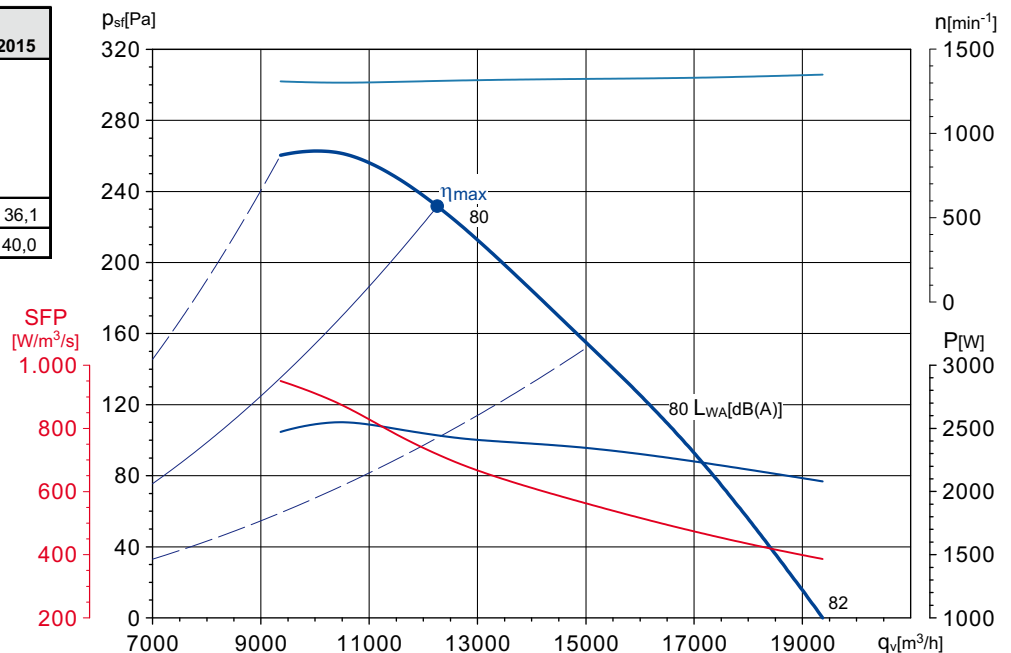

Hz	63	125	250	500	1000	2000	4000	8000	LwA
L	50	71	71	74	77	77	73	67	82
M	58	67	68	73	75	72	69	66	80
H	54	65	68	73	75	73	70	67	80



Soler&Palau
Ventilation Group