

HRST/8-800/33 BZ

IP54



Dimensiones y conexiones
Dimensions and wiring

Características Characteristics

Tensión <i>Voltage</i>	3 ~ 400V 50Hz	
Tipo motor <i>Motor type</i>	8 polos <i>8 poles</i>	IP54 cl.F
Potencia absorbida máxima <i>Maximum power absorbed</i>	1,1/0,7 kW	
Intensidad absorbida máxima <i>Maximum absorbed current</i>	2,4/1,3 A	
Condensador <i>Capacitor</i>		
Ia/In <i>Is/In</i>	3,3	
Temperatura del aire <i>Air temperature</i>	-40°C < T < +60°C	
Peso <i>Weight</i>	45,0 kg	
Código ventilador <i>Fan code number</i>	5720059800	
Código motor <i>Motor code number</i>	9024005204	

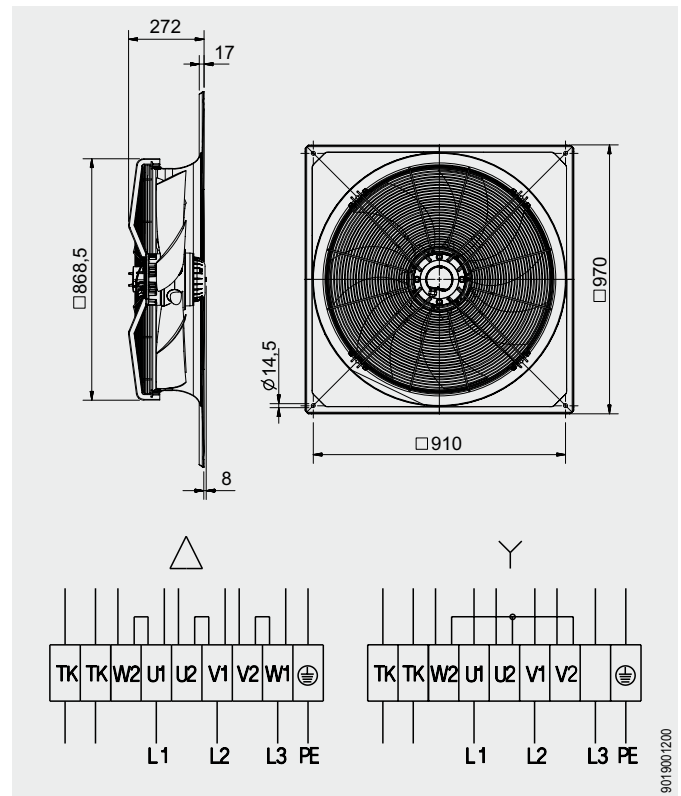

Curvas características / Performance curves (31/01/2009)

	Fan data	ErP	
		2013	2015
Installation category	A		
Efficiency category	Static		
VSD must be installed with the fan	No		
Specific ratio	1		
Overall efficiency [%]	30	29,8	33,8
Efficiency grade	36,2	36,0	40,0
Absorbed power [kW]	1,042		
Air volume [m ³ /h]	13032		
Static pressure [Pa]	87		
Speed [RPM]	665		

* Data at optimum efficiency working point

Norma ensayo: **ISO 5801**
Ventilador probado sin reja y con embocadura

Test standard: **ISO 5801**
Fan tested without guard and with bellmouth entry

Espectro de potencia (LwA) en dB(A) en la aspiración en punto de trabajo de presión baja (L), media (M), alta (H)

Sound power spectrum (LwA) in dB(A), at the fan inlet in low(L), medium(M) or high(H) pressure working point.

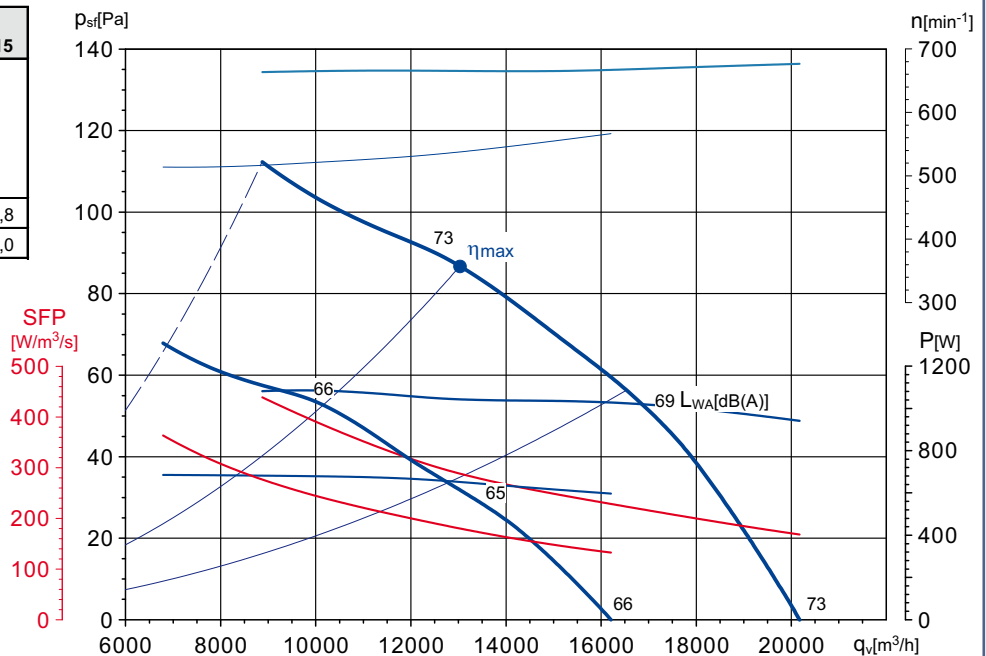

Hz	63	125	250	500	1000	2000	4000	8000	LwA
L	52	55	61	64	68	68	60	53	73
M	51	53	60	61	63	63	58	53	69
H	53	56	60	69	67	65	61	55	73

Hz	63	125	250	500	1000	2000	4000	8000	LwA
L	47	49	62	60	65	63	54	47	69
M	45	47	57	56	61	59	53	45	65
H	47	49	60	58	61	59	53	45	66



Soler&Palau
Ventilation Group