

# HRST/8-800/28 BZ

## IP54



### Dimensiones y conexiones

### Dimensions and wiring

### Características

### Characteristics

<b>Tensión</b> <b>Voltage</b>	3 ~ 400V 50Hz	
<b>Tipo motor</b> <b>Motor type</b>	8 polos <i>8 poles</i>	IP54 cl.F
<b>Potencia absorbida máxima</b> <b>Maximum power absorbed</b>	1,0 kW	
<b>Intensidad absorbida máxima</b> <b>Maximum absorbed current</b>	2,4 A	
<b>Condensador</b> <b>Capacitor</b>		
<b>Ia/In</b> <b>Is/In</b>	3,6	
<b>Temperatura del aire</b> <b>Air temperature</b>	-40°C < T < +70°C	
<b>Peso</b> <b>Weight</b>	45,0 kg	
<b>Código ventilador</b> <b>Fan code number</b>	5720062600	
<b>Código motor</b> <b>Motor code number</b>	9024005200	

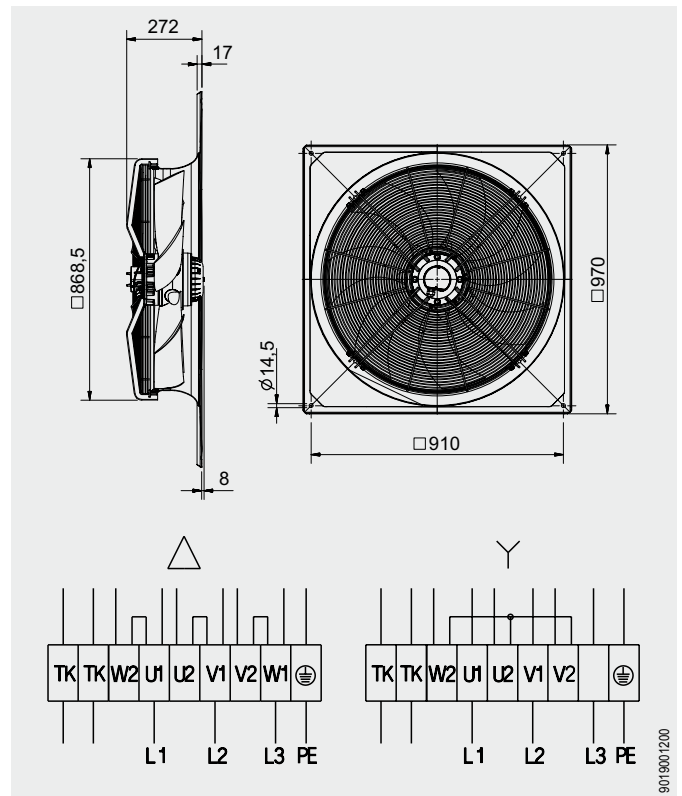

### Curvas características / Performance curves (15/04/2011)

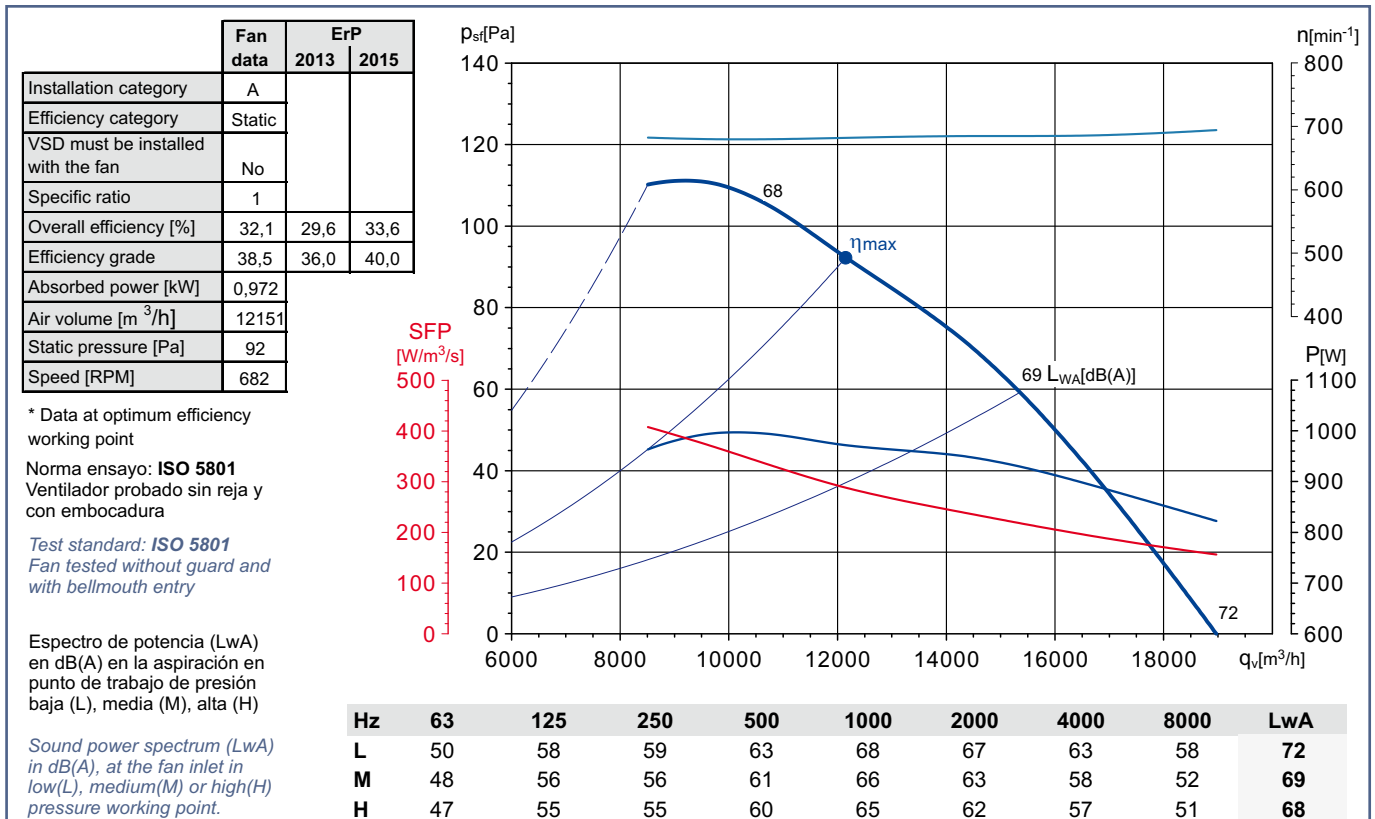

**Soler&Palau**  
Ventilation Group