

Min HTR Unit to wall

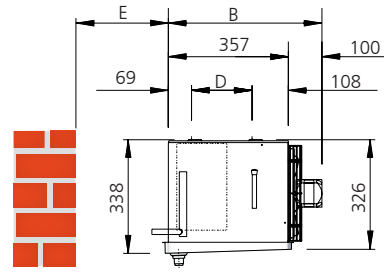

Heater removal
1000 Min

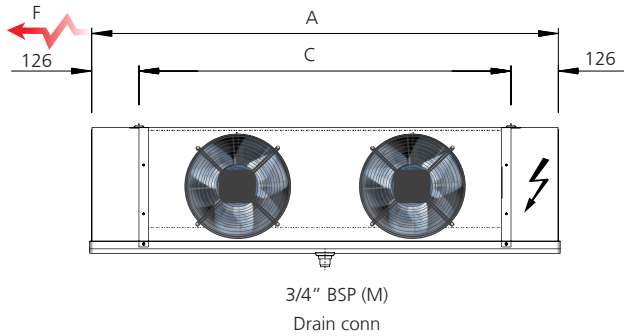

Key hole slot

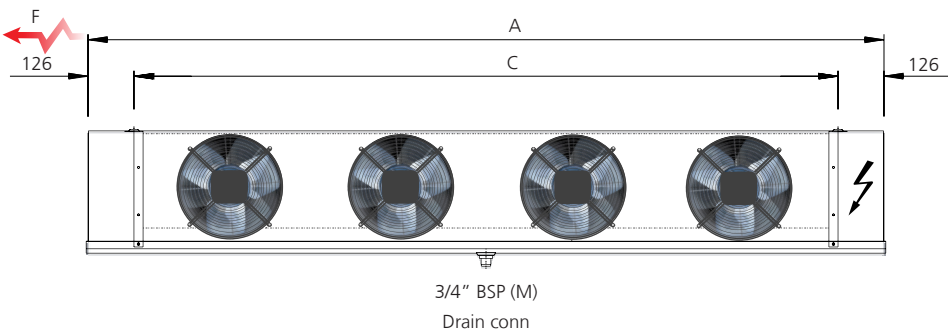
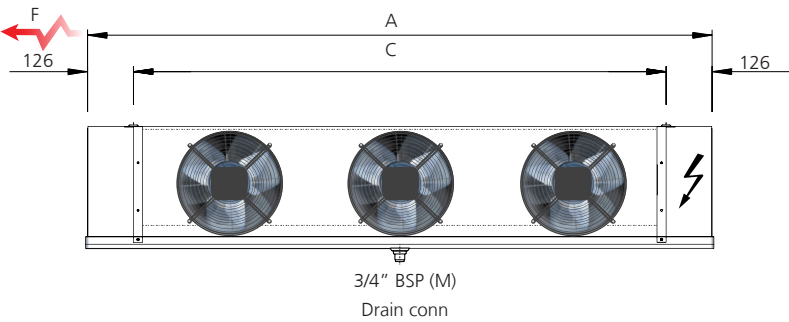
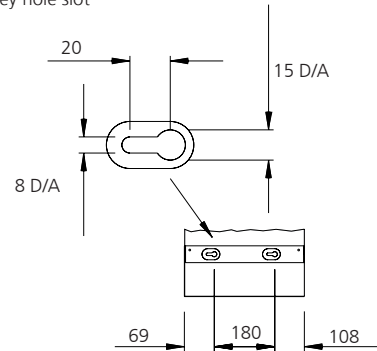

'F' = Min heat Withdrawal

| Model | Overall | | Mounting centres | | E | F | Dry Weight kg |
|----------|---------|-----|------------------|-----|-----|------|---------------|
| | A | B | C | D | | | |
| NS14 - 6 | 772 | 457 | 520 | 180 | 275 | 550 | 15 |
| NS25 - 6 | 1242 | 457 | 990 | 180 | 275 | 1020 | 22 |
| NS28 - 6 | 1242 | 457 | 900 | 180 | 275 | 1020 | 26 |
| NS37 - 6 | 1712 | 457 | 1460 | 180 | 275 | 1200 | 31 |
| NS43 - 6 | 1712 | 457 | 1460 | 180 | 275 | 1200 | 36 |
| NS57 - 6 | 2182 | 457 | 1930 | 180 | 275 | 1200 | 46 |