

R09_-3330H_-4M-3542

Diameter:

330 mm

Nominal data according to standard EN 60335:

Phase	1~
Nominal voltage	230 V
Frequency	50/60 Hz
Rated power input	130/170 W
Rated current	0.55/0.75 A
Rated speed	1350/1500 RPM
Min. ambient temperature	-30 °C
Max. ambient temperature	55 °C
Sound power level A weighted	70/74 dB (A)
Condensator	4 µF/450 V
Connection	terminal box
Insulation class	155
Protection class	IP54

ErP data according to EU regulation 327/2011:

Overall efficiency	25.9 %
Measurement category	A
Efficiency category	static
Efficiency grade N	37.8
Variable speed drive	NO
Power input	133 W
Air flow	1800 m³/h
Pressure drop	72 Pa
Speed	1350 RPM
Specific ratio	1.00

Aerodynamic characteristic

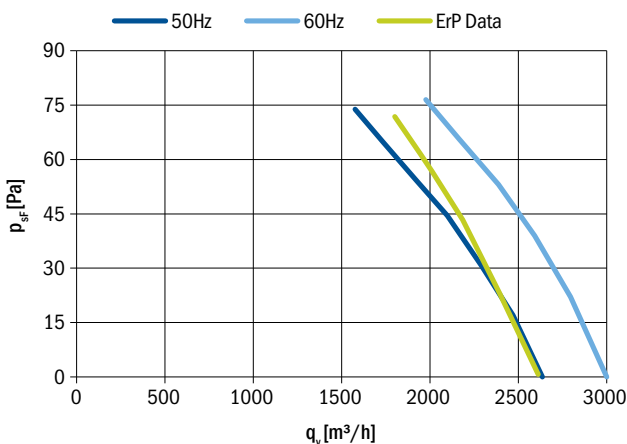

Fan characteristic measured in full bell mouth with guard grill
ErP characteristic measured in full bell mouth without guard grill

General notes

Connection diagram: Sucking	0301-1-0043	Page 145
Blowing	0301-1-0044	
Accessories		Page 134
Compliant to standards		Page 28



Fan with guard grill

Airflow Direction	Type	Code	Weight (kg)
Sucking	R09R-3330HA-4M-3542	0309-4-1001	3.4
Blowing	R09R-3330HP-4M-3542	On request	

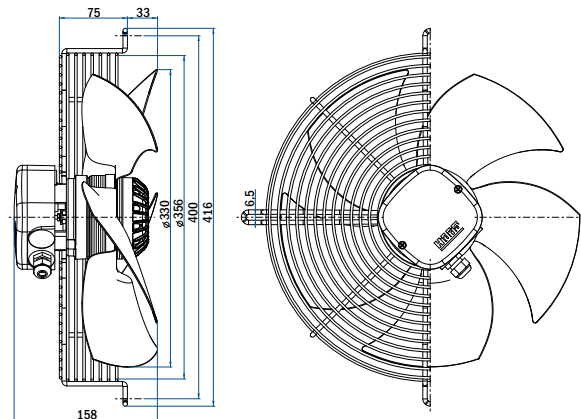

Fan with plate

Airflow Direction	Type	Code	Weight (kg)
Sucking	R09P-3330HA-4M-3542	On request	
Blowing	R09P-3330HP-4M-3542	On request	

Fan without guard grill

Airflow Direction	Type	Code	Weight (kg)
Sucking	R09E-3330HA-4M-3542	On request	
Blowing	R09E-3330HP-4M-3542	On request	