

Diameter:

350 mm

R09_-3530H_-4M-4237



Fan with guard grill

Airflow Direction	Type	Code	Weight (kg)
Sucking	R09R-3530HA-4M-4237	0309-4-1000	3.7
Blowing	R09R-3530HP-4M-4237	0309-4-1032	

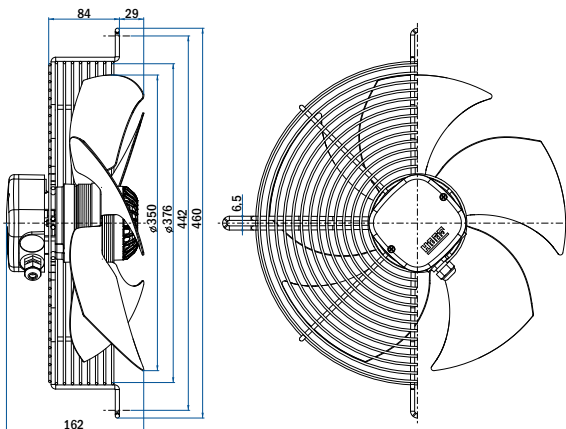

Fan with plate

Airflow Direction	Type	Code	Weight (kg)
Sucking	R09P-3530HA-4M-4237	0309-4-1013	6.2
Blowing	R09P-3530HP-4M-4237	0309-4-1122	

Fan without guard grill

Airflow Direction	Type	Code	Weight (kg)
Sucking	R09E-3530HA-4M-4237	On request	
Blowing	R09E-3530HP-4M-4237	On request	

Nominal data according to standard EN 60335:	
Phase	1~
Nominal voltage	230 V
Frequency	50/60 Hz
Rated power input	130/165 W
Rated current	0.60/0.72 A
Rated speed	1290/1380 RPM
Min. ambient temperature	-30 °C
Max. ambient temperature	60 °C
Sound power level A weighted	72/75 dB (A)
Condensator	4 µF/450 V
Connection	terminal box
Insulation class	155
Protection class	IP54

ErP data according to EU regulation 327/2011:	
Overall efficiency	29.0 %
Measurement category	A
Efficiency category	static
Efficiency grade N	40.7
Variable speed drive	NO
Power input	140 W
Air flow	1975 m³/h
Pressure drop	79 Pa
Speed	1333 RPM
Specific ratio	1.00

Aerodynamic characteristic

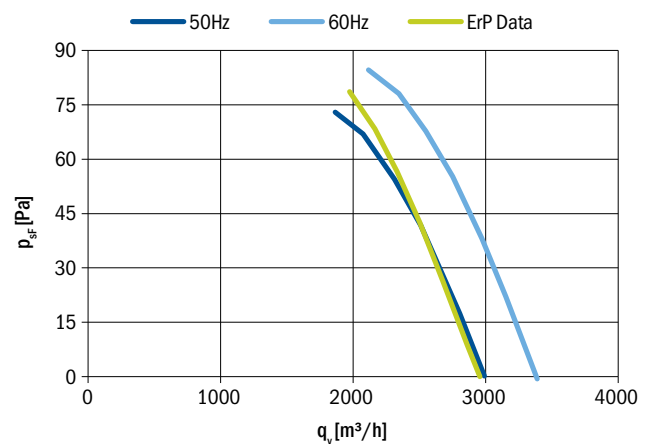

Fan characteristic measured in full bell mouth with guard grill
ErP characteristic measured in full bell mouth without guard grill

General notes		
Connection diagram: Sucking	0301-1-0043	Page 145
Blowing	0301-1-0044	
Accessories		Page 134
Compliant to standards		Page 28