

R09_-3530H_-4T-4258

Diameter:

350 mm

Nominal data according to standard EN 60335:

Phase	3~
Nominal voltage	400/230 V
Frequency	50/60 Hz
Rated power input	135/170 W
Rated current	0.30/0.53/0.30/0.53 A
Rated speed	1330/1460 RPM
Min. ambient temperature	-30 °C
Max. ambient temperature	65/70 °C
Sound power level A weighted	72/75 dB (A)
Connection	terminal box
Insulation class	155
Protection class	IP54

ErP data according to EU regulation 327/2011:

Overall efficiency	29.5 %
Measurement category	A
Efficiency category	static
Efficiency grade N	41.2
Variable speed drive	NO
Power input	141 W
Air flow	2107 m³/h
Pressure drop	74 Pa
Speed	1332 RPM
Specific ratio	1.00

Aerodynamic characteristic

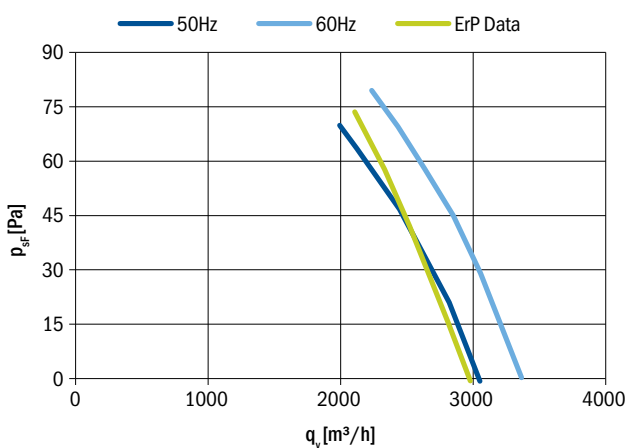

Fan characteristic measured in full bell mouth with guard grill
ErP characteristic measured in full bell mouth without guard grill

General notes

Connection diagram: Sucking	0301-1-0049	Page 146
Blowing	0301-1-0049	
Accessories		Page 134
Compliant to standards		Page 28



Fan with guard grill

Airflow Direction	Type	Code	Weight (kg)
Sucking	R09R-3530HA-4T-4258	0309-4-1023	3.7
Blowing	R09R-3530HP-4T-4258	0309-4-1048	

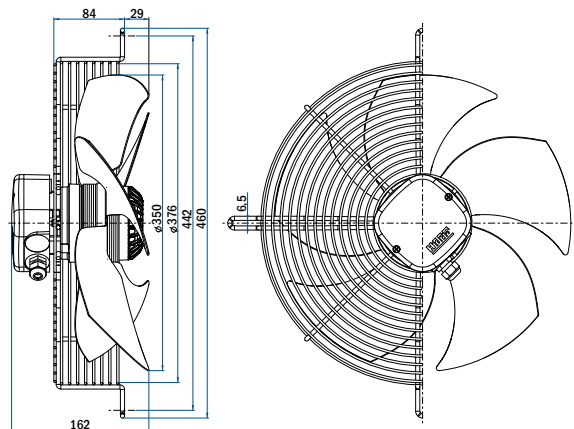

Fan with plate

Airflow Direction	Type	Code	Weight (kg)
Sucking	R09P-3530HA-4T-4258	On request	
Blowing	R09P-3530HP-4T-4258	On request	

Fan without guard grill

Airflow Direction	Type	Code	Weight (kg)
Sucking	R09E-3530HA-4T-4258	On request	
Blowing	R09E-3530HP-4T-4258	On request	