

R09_-3532_-4M-4237

Diameter:

350 mm

Nominal data according to standard EN 60335:

Phase	1~
Nominal voltage	230 V
Frequency	50/60 Hz
Rated power input	130/165 W
Rated current	0.58/0.72 A
Rated speed	1280/1350 RPM
Min. ambient temperature	-30 °C
Max. ambient temperature	70/65 °C
Sound power level A weighted	71/73 dB (A)
Condensator	4 µF/450 V
Connection	terminal box
Insulation class	155
Protection class	IP54

ErP data according to EU regulation 327/2011:

Overall efficiency	26.2 %
Measurement category	A
Efficiency category	static
Efficiency grade N	37.7
Variable speed drive	NO
Power input	149 W
Air flow	1889 m³/h
Pressure drop	78 Pa
Speed	1285 RPM
Specific ratio	1.00

Aerodynamic characteristic

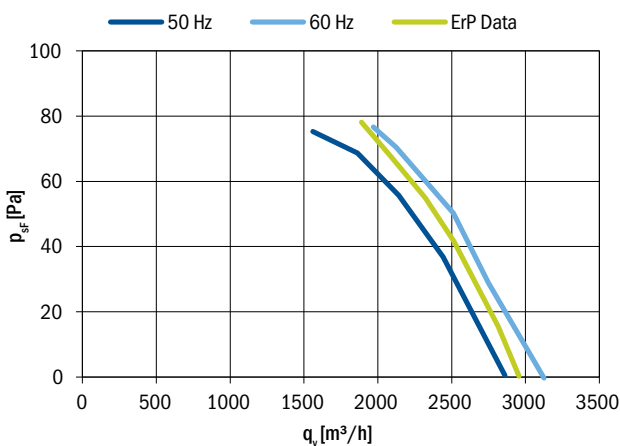

Fan characteristic measured in short bell mouth with guard grill.
ErP characteristic measured in full bell mouth without guard grill.

General notes

Connection diagrams:		
Sucking	0301-1-0043	See section
Blowing	0301-1-0044	Connection diagrams
Guard grills & wall-plates	See section Accessories	
Standards compliance	See introduction page	



Fan with guard grill

Airflow Direction	Type	Code	Weight (kg)
Sucking	R09R-3532A-4M-4237	0309-4-0108	4.0
Blowing	R09R-3532P-4M-4237	0309-4-0221	

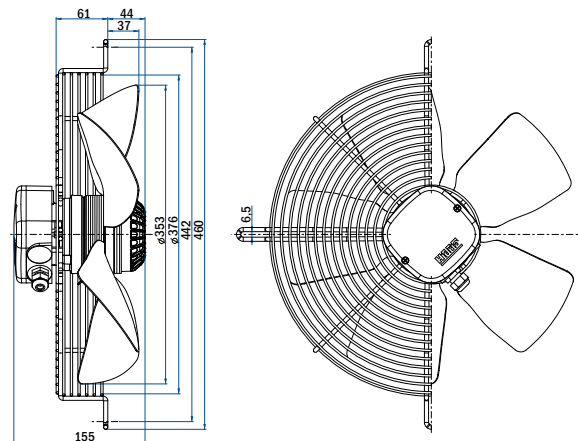

Fan with plate

Airflow Direction	Type	Code	Weight (kg)
Sucking	R09P-3532A-4M-4237	On request	
Blowing	R09P-3532P-4M-4237	On request	

Fan without guard grill

Airflow Direction	Type	Code	Weight (kg)
Sucking	R09E-3532A-4M-4237	On request	
Blowing	R09E-3532P-4M-4237	On request	