

R11_-3530_-4M-3852

Diameter:

350 mm

Nominal data according to standard EN 60335:

Phase	1~
Nominal voltage	230 V
Frequency	50/60 Hz
Rated power input	175/210 W
Rated current	0.8/1.15 A
Rated speed	1410/1570 RPM
Min. ambient temperature	-30 °C
Max. ambient temperature	60/50 °C
Sound power level A weighted	
Condensator	4 µF/450 V
Connection	terminal box
Insulation class	155
Protection class	IP54

ErP data according to EU regulation 327/2011:

Overall efficiency	29.0 %
Measurement category	A
Efficiency category	static
Efficiency grade N	40.2
Variable speed drive	NO
Power input	170 W
Air flow	2012 m³/h
Pressure drop	93 Pa
Speed	1411 RPM
Specific ratio	1.00

Aerodynamic characteristic

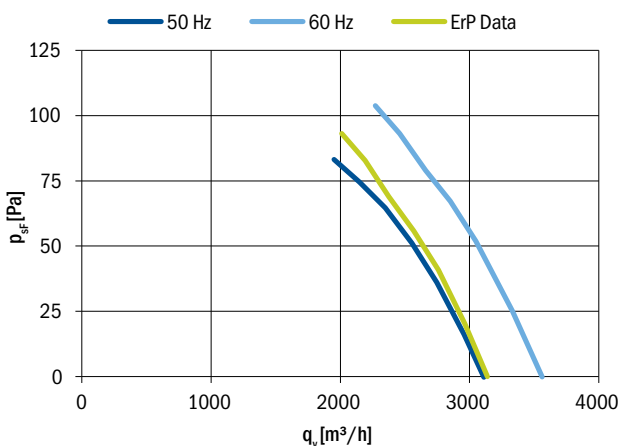

Fan characteristic measured in short bell mouth with guard grill.
ErP characteristic measured in full bell mouth without guard grill.

General notes

Connection diagrams:		
Sucking	0301-1-0043	See section
Blowing	0301-1-0044	Connection diagrams
Guard grills & wall-plates	See section Accessories	
Standards compliance	See introduction page	



Fan with guard grill

Airflow Direction	Type	Code	Weight (kg)
Sucking	R11R-3530A-4M-3852	0311-4-0297	6.0
Blowing	R11R-3530P-4M-3852	0311-4-0404	

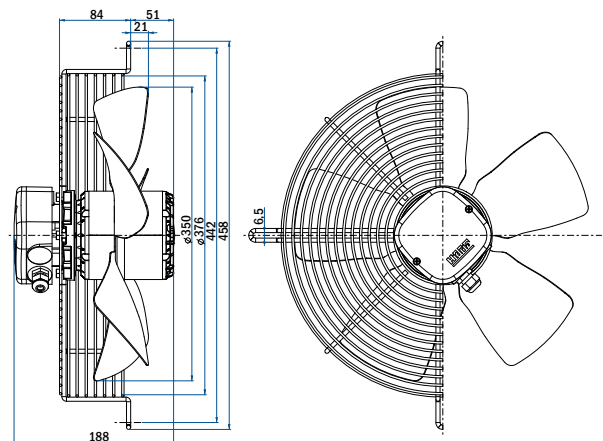

Fan with plate

Airflow Direction	Type	Code	Weight (kg)
Sucking	R11P-3530A-4M-3852	On request	
Blowing	R11P-3530P-4M-3852	On request	

Fan without guard grill

Airflow Direction	Type	Code	Weight (kg)
Sucking	R11E-3530A-4M-3852	On request	
Blowing	R11E-3530P-4M-3852	On request	