

**R13\_-4530H\_-4T2-5059**

**Diameter:**

**450 mm**

**Nominal data according to standard EN 60335:**

Phase	3~
Nominal voltage	400 V
Frequency	50 Hz
Speed	high/low
Rated power input	465/330 W
Rated current	0.95/0.50 A
Rated speed	1400/1260 RPM
Min. ambient temperature	-30 °C
Max. ambient temperature	70 °C
Sound power level A weighted	73/69 dB (A)
Connection	terminal box
Insulation class	155
Protection class	IP54

**ErP data according to EU regulation 327/2011:**

Overall efficiency	29.3 %
Measurement category	A
Efficiency category	static
Efficiency grade N	37.5
Variable speed drive	NO
Power input	500 W
Air flow	4631 m³/h
Pressure drop	118 Pa
Speed	1372 RPM
Specific ratio	1.00

**Aerodynamic characteristic**

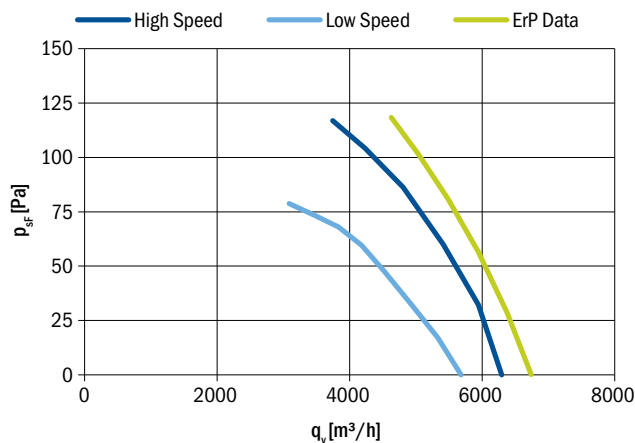

Fan characteristic measured in full bell mouth with guard grill.

ErP characteristic measured in full bell mouth without guard grill.

**General notes**

Connection diagrams:

Sucking 0301-1-0033 See section  
Blowing 0301-1-0033 Connection diagrams

Guard grills & wall-plates See section Accessories

Standards compliance See introduction page



**Fan with guard grill**

Airflow Direction	Type	Code	Weight (kg)
Sucking	R13R-4530HA-4T2-5059	0313-4-1152	11.0
Blowing	R13R-4530HP-4T2-5059	On request	

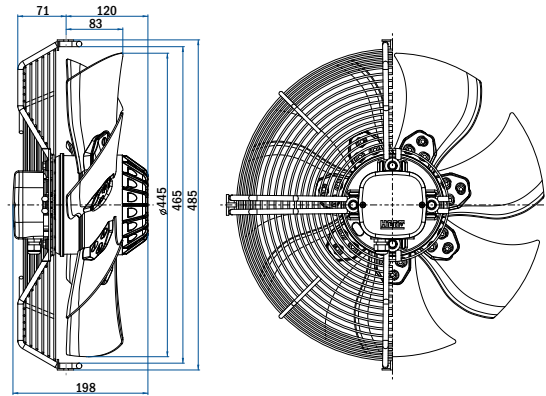

**Fan with plate**

Airflow Direction	Type	Code	Weight (kg)
Sucking	R13P-4530HA-4T2-5059	On request	
Blowing	R13P-4530HP-4T2-5059	On request	

**Fan without guard grill**

Airflow Direction	Type	Code	Weight (kg)
Sucking	R13E-4530HA-4T2-5059	On request	
Blowing	R13E-4530HP-4T2-5059	On request	