

Diameter:

500 mm

R13\_-5030H\_-4T2-70101



**Fan with guard grill**

Airflow Direction	Type	Code	Weight (kg)
Sucking	R13R-5030HA-4T2-70101	0313-4-1038	12.5
Blowing	R13R-5030HP-4T2-70101	On request	

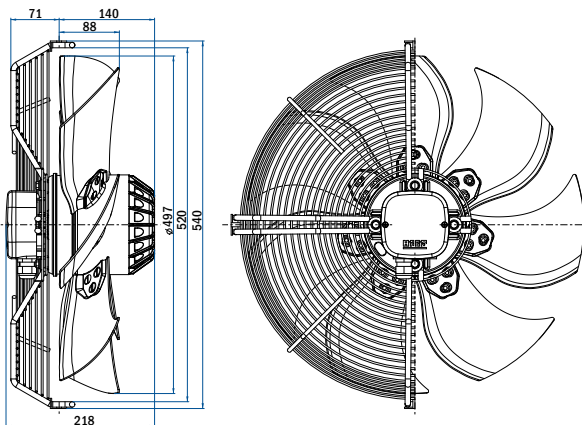

**Fan with plate**

Airflow Direction	Type	Code	Weight (kg)
Sucking	R13P-5030HA-4T2-70101	0313-4-1028	18.0
Blowing	R13P-5030HP-4T2-70101	On request	

**Fan without guard grill**

Airflow Direction	Type	Code	Weight (kg)
Sucking	R13E-5030HA-4T2-70101	0313-4-1068	10.1
Blowing	R13E-5030HP-4T2-70101	On request	

Nominal data according to standard EN 60335:	
Phase	3~
Nominal voltage	400 V
Frequency	50 Hz
Speed	high/low
Rated power input	770/590 W
Rated current	1.6/0.96 A
Rated speed	1380/1165 RPM
Min. ambient temperature	-30 °C
Max. ambient temperature	55/65 °C
Sound power level A weighted	76/72 dB (A)
Connection	terminal box
Insulation class	155
Protection class	IP54

ErP data according to EU regulation 327/2011:	
Overall efficiency	31.1 %
Measurement category	A
Efficiency category	static
Efficiency grade N	40.2
Variable speed drive	NO
Power input	745 W
Air flow	6519 m <sup>3</sup> /h
Pressure drop	141 Pa
Speed	1390 RPM
Specific ratio	1.00

**Aerodynamic characteristic**

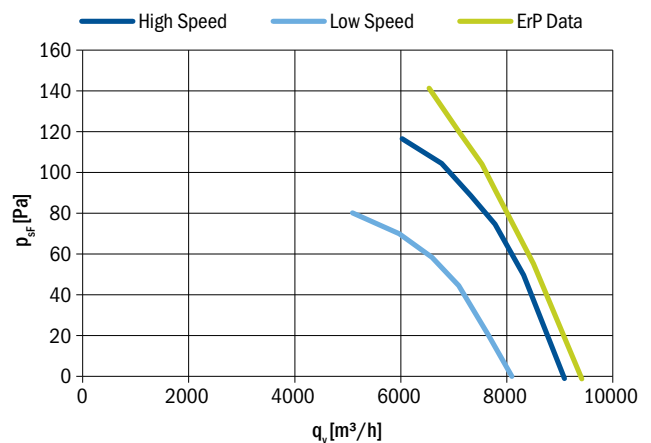

Fan characteristic measured in full bell mouth with guard grill.  
ErP characteristic measured in full bell mouth without guard grill.

General notes	
Connection diagrams:	
Sucking	0301-1-0033 See section
Blowing	0301-1-0033 Connection diagrams
Guard grills & wall-plates	See section Accessories
Standards compliance	See introduction page