

R13_-5030H_-6T2-5068

Diameter:

500 mm

Nominal data according to standard EN 60335:

Phase	3~
Nominal voltage	400 V
Frequency	50 Hz
Speed	high/low
Rated power input	210/150 W
Rated current	0.60/0.27 A
Rated speed	960/880 RPM
Min. ambient temperature	-30 °C
Max. ambient temperature	60 °C
Sound power level A weighted	72/70 dB (A)
Connection	terminal box
Insulation class	155
Protection class	IP54



Aerodynamic characteristic

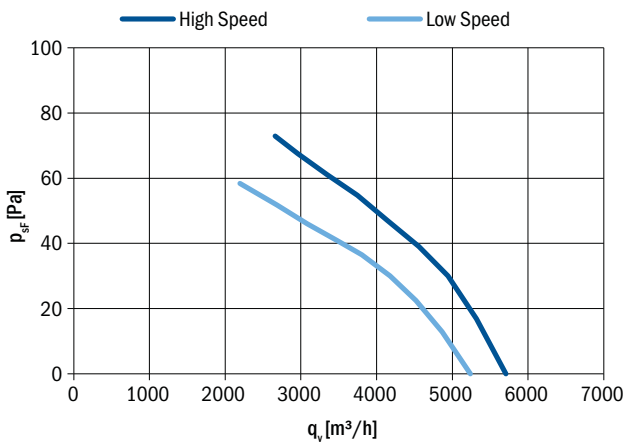

Fan characteristic measured in full bell mouth with guard grill

Fan with guard grill

Airflow Direction	Type	Code	Weight (kg)
Sucking	R13R-5030HA-6T2-5068	0313-4-1089	10.3
Blowing	R13R-5030HP-6T2-5068	On request	

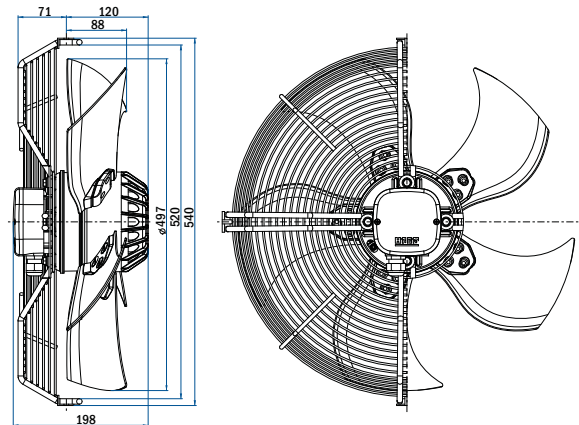

Fan with plate

Airflow Direction	Type	Code	Weight (kg)
Sucking	R13P-5030HA-6T2-5068	0313-4-1090	15.8
Blowing	R13P-5030HP-6T2-5068	On request	

Fan without guard grill

Airflow Direction	Type	Code	Weight (kg)
Sucking	R13E-5030HA-6T2-5068	0313-4-1088	7.9
Blowing	R13E-5030HP-6T2-5068	On request	

General notes

Connection diagram: Sucking	0301-1-0033	Page 147
Blowing	0301-1-0033	
Accessories		Page 134
Compliant to standards		Page 28