

Diameter:

630 mm

R13\_-6330H\_-6T2-7042



### Fan with guard grill

Airflow Direction	Type	Code	Weight (kg)
Sucking	R13R-6330HA-6T2-7042	0313-4-1000	14.5
Blowing	R13R-6330HP-6T2-7042	On request	

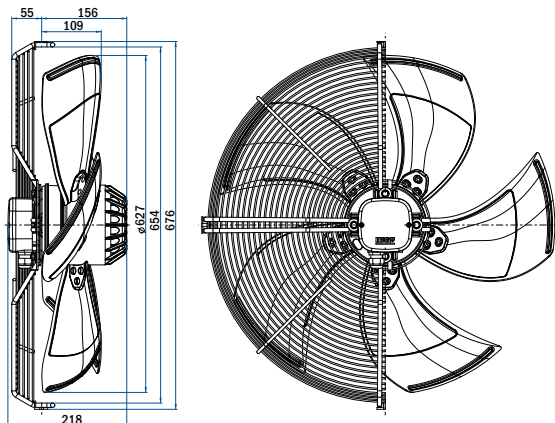

### Fan with plate

Airflow Direction	Type	Code	Weight (kg)
Sucking	R13P-6330HA-6T2-7042	0313-4-1013	23.3
Blowing	R13P-6330HP-6T2-7042	On request	

### Fan without guard grill

Airflow Direction	Type	Code	Weight (kg)
Sucking	R13E-6330HA-6T2-7042	0313-4-1042	10.8
Blowing	R13E-6330HP-6T2-7042	On request	

Nominal data according to standard EN 60335:	
Phase	3~
Nominal voltage	400 V
Frequency	50 Hz
Speed	high/low
Rated power input	600/380 W
Rated current	1.25/0.65 A
Rated speed	870/640 RPM
Min. ambient temperature	-30 °C
Max. ambient temperature	40 °C
Sound power level A weighted	77/73 dB (A)
Connection	terminal box
Insulation class	155
Protection class	IP54

ErP data according to EU regulation 327/2011:	
Overall efficiency	31.8 %
Measurement category	A
Efficiency category	static
Efficiency grade N	39.2
Variable speed drive	NO
Power input	680 W
Air flow	7593 m <sup>3</sup> /h
Pressure drop	107 Pa
Speed	877 RPM
Specific ratio	1.00

### Aerodynamic characteristic

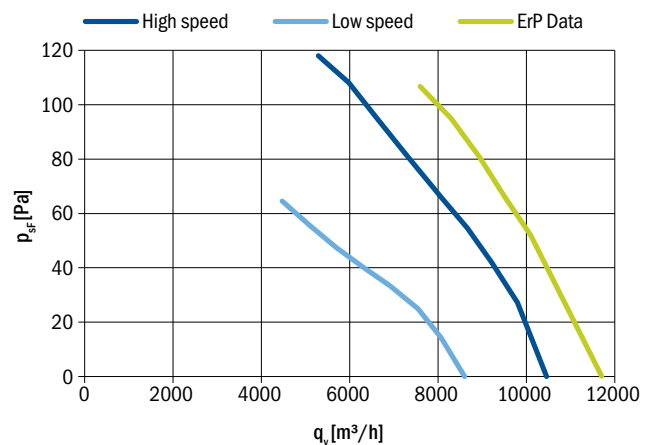

Fan characteristic measured in full bell mouth with guard grill  
ErP characteristic measured in full bell mouth without guard grill

General notes		
Connection diagram: Sucking	0301-1-0033	Page 147
Blowing	0301-1-0033	
Accessories		Page 134
Compliant to standards		Page 28