

# XA100C

## Multi probes digital Indicator



### 1. GENERAL WARNING

#### 1.1 PLEASE READ BEFORE USING THIS MANUAL

- This manual is part of the product and should be kept near the instrument for easy and quick reference.
- The instrument shall not be used for purposes different from those described hereunder. It cannot be used as a safety device.
- Check the application limits before proceeding.
- Dixell Srl reserves the right to change the composition of its products, even without notice, ensuring the same and unchanged functionality

#### 1.2 SAFETY PRECAUTIONS

- Check the supply voltage is correct before connecting the instrument.
- Do not expose to water or moisture; use the controller only within the operating limits avoiding sudden temperature changes with high atmospheric humidity to prevent formation of condensation
- Warning: disconnect all electrical connections before any kind of maintenance.
- The instrument must not be opened.
- In case of failure or faulty operation send the instrument back to the distributor or to "DIXELL S.r.l." (see address) with a detailed description of the fault.
- Ensure that the wires for probes, loads and the power supply are separated and far enough from each other, without crossing or intertwining.
- In case of applications in industrial environments, the use of mains filters (our mod. FT1) in parallel with inductive loads could be useful.

### 2. GENERAL DESCRIPTION

The XA100C is a multi probes digital indicator for temperature, humidity and pressure applications. The analogue input type can be set by parameter between the following, according to the model:

- PTC, NTC;
- PTC, NTC, Pt100, Thermocouple J, K, S;
- 4+20mA, 0+1V, 0+10V.

### 3. FIRST INSTALLATION

#### 3.1 PROBE SETTING



The pre-set probe type is written on the label of the instrument, see picture. If it is different from the probe that

has been used, set the probe following procedure below

##### 3.1.1 How to set the probe.

- Enter the programming menu by pressing the SET + n for 3s.
- Select the Pbc (Probe configuration) parameter and push the SET key.
- Set the kind of probe:
  - Controller for temperature: Pt= Pt100, J = J thermocouple, c = K thermocouple, S = S thermocouple; Ptc = PTC; ntc = ntc.
  - Controller with current or voltage inputs: cur=4+20mA, 0-1= 0+1V, 10= 0+10V
- Push the SET key to confirm it.
- Switch the controller off and on again.

### 4. FRONT PANEL COMMANDS

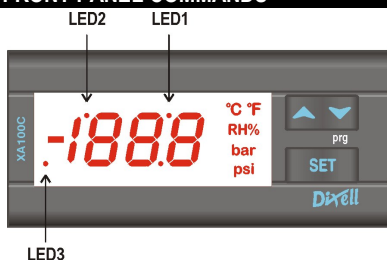

SET: in normal mode is not used. In programming mode is used to select parameters or confirm a value.

**TO SWITCH THE INSTRUMENT ON/OFF:** If the function is enabled (par. onF=yES), by pressing the SET key for more than 4s the controller is switched OFF. To switch the instrument on again press the SET key.

**o UP:** in programming mode it browses the parameter codes or increases the displayed value. Hold it pressed for a faster change

**n DOWN:** in programming mode it browses the parameter codes or decreases the displayed value. Hold it pressed for a faster change

#### KEY COMBINATIONS:

- o + n** To lock & unlock the keyboard.
- SET + n** To enter in programming mode.
- SET + o** To return to the room temperature display.

#### 4.1 USE OF LEDS

Each LED function is described in the following table.

LED	MODE	FUNCTION
LED1	Flashing	- Programming Phase (flashing with LED2)
LED2	Flashing	- Programming Phase (flashing with LED1)
LED3	ON	- ALARM signal - In "Pr2" indicates the parameter is also present in "Pr1"

#### 4.2 TO ENTER THE PARAMETERS LIST "PR1"

To enter the parameter list "Pr1" (user accessible parameters) operate as follows:

- Push for 3s the SET + n keys (LED1 & 2 start blinking).
- The controller will display the first parameter present in the Pr1 menu..

#### 4.3 TO ENTER THE PARAMETERS LIST "PR2"

The "Pr2" parameter list contains the configuration parameters. A security code is required to enter it.

- Enter the "Pr1" level, see above paragraph.
- Select "Pr2" parameter and press the "SET" key.
- The "PAS" flashing message is displayed, shortly followed by "0 -" with a flashing zero.
- Use o or n to input the security code in the flashing digit; confirm the figure by pressing "SET".

#### The security code is "321".

- If the security code is correct the access to "Pr2" is enabled by pressing "SET" on the last digit.

Another possibility is the following:

After switching ON the instrument, within 30 seconds, push SET + n keys together for 3s: the Pr2 menu will be entered.

#### 4.4 HOW TO MOVE A PARAMETER FROM THE "PR2" MENU TO "PR1" AND VICEVERSA.

Each parameter present in "Pr2" MENU can be removed or put into "Pr1", user level, by pressing "SET + n".  
In "Pr2" when a parameter is present in "Pr1" the LED3 is on.

#### 4.5 HOW TO CHANGE A PARAMETER

To change a parameter value operates as follows:

- Enter the Programming mode
- Select the required parameter.
- Press the "SET" key to display its value.
- Use "UP" or "DOWN" to change its value.
- Press "SET" to store the new value and move to the following parameter.

**TO EXIT:** Press SET + UP or wait 15s without pressing a key.

**NOTE:** the set value is stored even when the procedure is exited by waiting the time-out to expire.

#### 4.6 HOW TO LOCK THE KEYBOARD



- Keep pressed for more than 3 s the o and n keys. The "POF" message will be displayed and the keyboard will be locked.
- If a key is pressed more than 3s the "POF" message will be displayed.

#### 4.7 TO UNLOCK THE KEYBOARD

Keep pressed together for more than 3s the o and n keys, till the "Pon" message will be displayed.

#### 4.8 ON/OFF FUNCTION

**TO SWITCH THE INSTRUMENT ON/OFF:** If the function is enabled (par. onF=yES), by pressing the SET key for more than 4s the controller is switched OFF. To switch the instrument on again press the SET key.

### 5. PROBES AND MEASURING RANGE

Probe	Down Scale	Full Scale
NTC	-40°C/-40°F	110°C / 230 °F

PTC	-50°C / -58°F	150°C / 302°F
Pt100	-200°C / -328°F	600°C / 1112°F
TcK	0°C / 32°F	1300°C / 1999°F
TcJ	0°C / 32°F	600°C / 1112°F
TcS	0°C / 32°F	1400°C / 1999°F

### 6. LIST OF PARAMETERS

#### PROBES AND DISPLAY

**LCI Start of scale, only with current or voltage input:** (-1999+1999) Adjustment of read out corresponding to 4mA or 0V input signal.

**UCI End of scale, only with current or voltage input** (-1999+1999) Adjustment of read out corresponding to 20mA or 1V or 10V input signal.

**oPb Probe calibration:** (-999+999) allows to adjust possible offset of the probe.

**rES Decimal point ON/OFF:** (rES=in OFF; rES=dE ON; rES=cE with 2 decimal points, only for current or voltage input) select the resolution of the controller.

**NOTE:** the decimal point selection is not available on models with thermocouple input.

**UdM Measurement unit:** it depends on models:

for temperature: °C = Celsius; °F = Fahrenheit.

with 4+20mA, 0+1V, 0+10V input : 0= °C; 1= °F, 2= %RH, 3=bar, 4=PSI, 5=no measurement unit.

**Pbc Probe selection:** it sets the kind of probe. It depends on models  
for temperature NTC/PTC: Ptc = PTC; ntc = ntc.

for temperature standard: Pt= Pt100, J = J thermocouple, c = K thermocouple, S = S thermocouple; Ptc = PTC; ntc = ntc.  
with 4+20mA, 0+1V, 0+10V input : cur=4+20mA, 0-1= 0+1V, 10= 0+10V.

**P3F Third wire presence for Pt100 probe:** for using 2 or 3 wires Pt100 probes: no = 2 wires probe; yES = 3 wires probe.

#### DIGITAL INPUT

**i1F Digital input operating mode:** configure the digital input function: c-H = Not used; oFF = to switch the controller off; AUS = Not used; HES = Not used; EAL = external alarm; bAL = external alarm..

**i1P Digital input polarity:**

- CL : the digital input is activated by closing the contact;
- OP : the digital input is activated by opening the contact

**did Digital input alarm delay:** (0+255 min) delay between the detection of the external alarm condition (i1F= EAL or i1F = bAL) and its signalling.

#### OTHER

**Adr RS485 serial address (0+247)** identifies the instrument within a control or supervising system.

**onF Switching ON/OFF enabling from keyboard:** (no = disabled; yES=enabled) It permits the switching ON/OFF of the instrument by pressing the SET key for more than 4s.

**Ptb Parameters table:** (read only) Shows the code of the parameters map.

**rEL Software release:** (read only)

**Pr2 To access the Pr2 parameter programming menu.**

### 7. INSTALLATION AND MOUNTING

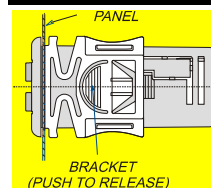

Instrument XA100C shall be mounted on vertical panel, in a 29x71 mm hole, and fixed using the special brackets supplied. To obtain an IP65 protection grade use the front panel rubber gasket (mod. RG-C).

The temperature range allowed for correct operation is 0+60 °C. Avoid places subject to strong vibrations, corrosive gases, excessive dirt or humidity. The same recommendations apply to probes. Let air circulate by the cooling holes.

### 8. ELECTRICAL CONNECTIONS

The instruments are provided with screw terminal block to connect cables with a cross section up to 2,5 mm<sup>2</sup>. Before connecting cables make sure the power supply complies with the instrument's requirements. Separate the input connection cables from the power supply cables and the power connections.

### 9. SERIAL CONNECTIONS

All models can be connected to the monitoring and supervising system XJ500 using the serial port. The external XJ485 serial module to interface the instrument with the monitoring and supervising system XJ500 is required. The standard ModBus RTU protocol it is used.

### 10. HOW TO USE THE HOT KEY

#### 10.1 HOW TO PROGRAM A HOT KEY FROM THE INSTRUMENT (UPLOAD)

- Program one controller with the front keypad.

- When the controller is ON, insert the "Hot key" and push o key; the "uPL" message appears followed a by flashing "End"
- Push "SET" key and the End will stop flashing.
- Turn OFF the instrument remove the "Hot Key", then turn it ON again.

**NOTE:** the "Err" message is displayed for failed programming. In this case push again o key if you want to restart the upload again or remove the "Hot key" to abort the operation.

**10.2 HOW TO PROGRAM AN INSTRUMENT USING A HOT KEY (DOWNLOAD)**

- Turn OFF the instrument.
- Insert a programmed "Hot Key" into the 5 PIN receptacle and then turn the Controller ON.
- Automatically the parameter list of the "Hot Key" is downloaded into the Controller memory, the "doL" message is blinking followed a by flashing "End".
- After 10 seconds the instrument will restart working with the new parameters.
- Remove the "Hot Key"..

**NOTE** the message "Err" is displayed for failed programming. In this case turn the unit off and then on if you want to restart the download again or remove the "Hot key" to abort the operation.

**11. DIGITAL INPUT**

XA100C has 1 free contact digital input. It is programmable in 3 different configurations by the "i1F" parameter.

**11.1 REMOTE ON/OFF (i1F = OFF)**

This function allows to switch ON and OFF the instrument.

**11.2 GENERIC ALARM (i1F = EAL)**

As soon as the digital input is activated the unit will wait for "did" time delay before signalling the "EAL" alarm message. The outputs status don't change. The alarm stops just after the digital input is deactivated.

**11.3 SERIOUS ALARM MODE (i1F = BAL)**

When the digital input is activated, the unit will wait for "did" delay before signalling the "bAL" alarm message.

**12. ALARM SIGNALS**

Message	Cause
"PFo"	Probe broken or absence
"PFc"	Probe short circuited
"EAL"	External alarm
"bAL"	Serious external alarm

**12.1 SILENCING BUZZER**

Once the alarm signal is detected the buzzer, if present, can be disabled by pressing any key. The display signal remains as long as the alarm condition remains.

**12.2 ALARM RECOVERY**

Probe alarms "PFo", "PFc" start few seconds after the fault in the probe; they automatically stop few seconds after the probe restarts normal operation. Check connections before replacing the probe. Alarms "bAL" and "EAL" recover as soon as the digital input is disabled.

**13. TECHNICAL DATA**

**Housing:** self extinguishing ABS.  
**Case:** frontal 32x74 mm; depth 60mm;  
**Mounting:** panel mounting in a 71x29 mm panel cut-out.  
**Protection:** IP20.  
**Frontal protection:** IP65 with frontal gasket RG-C (optional).  
**Connections:** Screw terminal block ≤ 2,5 mm<sup>2</sup> heat-resistant wiring.  
**Power supply:** 12Vac/dc, ±10% or: 24Vac/dc ± 10% or 230Vac ± 10%, 50/60Hz or 110Vac, ± 10%, 50/60Hz  
**Power absorption:** 3VA max.  
**Display:** 3 ½ digits, red LED  
**Inputs:** according to the order: NTC/PTC or NTC/PTC /Pt100 /Thermocouple J, K, S or 4+20mA/ 0+1V / 0+10V  
**Other output:** buzzer (optional)  
**Pollution grade:** normal, **Software class:** A.  
**Data storing:** on the non-volatile memory (EEPROM).  
**Operating temperature:** 0+60 °C (32+140°F).  
**Storage temperature:** -30+85 °C (-22+185°F).  
**Relative humidity:** 20+85% (no condensing)  
**Measuring range:** according to the probe

Controller Accuracy a 25°C: better than ±0,5% of full scale

**14. CONNECTIONS**

**14.1 XA100C – 12V AC/DC OR 24V AC/DC**

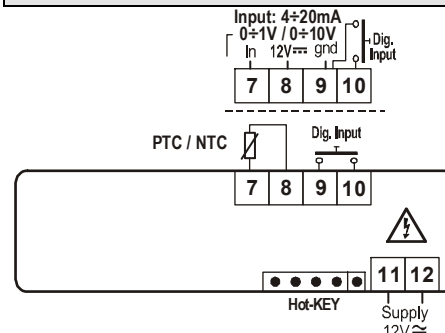

Probe: Pt100= 7 – 9 (8); Thermocouple J, K, S = 7(+); 9(-)  
 24Vac/dc supply: 11-12

**14.2 XA100C – 230V AC OR 115V AC**

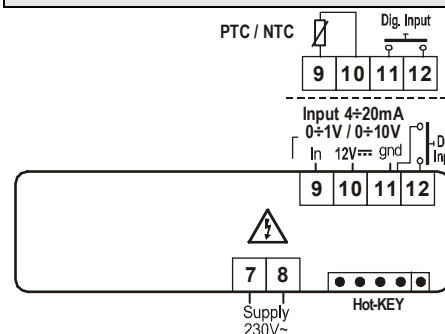

Pt100=9 – 11 (10); Thermocouple J, K, S = 9(+)- 11(-)  
 115Vac supply: 7-8

**15. DEFAULT SETTING VALUES**

COD	Name	Range	°C/°F	Lev
Lci <sup>2</sup>	Start scale with current or voltage input	-1999+1999	various	Pr1
Uci <sup>2</sup>	End scale with current or voltage input	-1999+1999	various	Pr1
OPb	Probe calibration	-Full Sc./ Full Sc.	0.0	Pr1
rES	Resolution	in=NO; dE=0,1; cE=0,01	in	Pr2
UdM	Measurement unit (temp.) (current/voltage)	°C=°C; °F=°F; 0=°C; 1=°F; 2=RH; 3=bar; 4=PSI; 5=off	various	Pr1
PbC	Kind of probe	Pt=Pt100; J=tcJ; c= tck; S=tcS; Ptc=PTC; ntc= NTC; 0-1=0+1V; 10= 0+10V; cur=4+20mA	various	Pr1
P3F	3 <sup>rd</sup> wire presence	no=2 wires; yES=3 wires	no	Pr2
i1F	Digital input configuration	c-H / oFF / AuS / HES / EAL / bAL	EAL	Pr2
i1P	Digital input polarity	cL=closed; oP=open	cL	Pr2
did	Alarm delay for dig. input	0+255 m	0	Pr2
Adr	Serial address	0+247	1	Pr2
OnF	oFF function enabling	no=not enabled; yES=enabled	no	Pr2
Ptb	Parameter table	Readable only	--	Pr2
rEL	Software release	Readable only	---	Pr2
Pr2	To access the Pr2	Readable only	321	Pr1

<sup>2</sup> Only for instrument with 4+20mA or 0+1V or 0+10V

Dixell S.r.l. - 32010 Pieve d'Alpago (BL) ITALY - Z.I. Via dell'Industria, 27  
 Tel. +39.0437.9833 r.a. - Fax +39.0437.989313 - www.dixell.com - dixell@emerson.com