

XM440K

XM460K

1. GENERAL WARNING

1.1 PLEASE READ BEFORE USING THIS MANUAL

- This manual is part of the product and should be kept near the instrument for easy and quick reference. The instrument shall not be used for purposes different from those described hereunder. It cannot be used as a safety device.
- Check the application limits before proceeding.

1.2 SAFETY PRECAUTIONS

- Check the supply voltage is correct before connecting the instrument.
- Do not expose to water or moisture: use the controller only within the operating limits avoiding sudden temperature changes with high atmospheric humidity to prevent formation of condensation
- Warning: disconnect all electrical connections before any kind of maintenance.
- Fit the probe where it is not accessible by the End User. The instrument must not be opened.
- In case of failure or faulty operation send the instrument back to the distributor or to "Dixell s.r.l." (see address) with a detailed description of the fault.
- Consider the maximum current which can be applied to each relay (see Technical Data).
- Ensure that the wires for probes, loads and the power supply are separated and far enough from each other, without crossing or intertwining.
- In case of applications in industrial environments, the use of mains filters (our mod. FT1) in parallel with inductive loads could be useful.

2. GENERAL DESCRIPTION

Models **XM440K** and **XM460K** are microprocessor based controllers suitable for applications on medium or low temperature multiplexed cabinets made of up to 5 units. They can be inserted in a LAN of up to 5 different sections which can operate, depending on the programming, as stand alone controllers or following the commands coming from one of the other sections. XM440K is provided with 3 relay outputs to control the solenoid valve, defrost - which can be either electrical or hot gas and the lights while XM460K is also provided with a relay output to control the evaporator fans. They are also provided with three NTC probe inputs, one for temperature control, one to control the defrost end temperature of the evaporator and the third, optional, for the display. There are two digital inputs (free contact) : one devoted to the Energy saving activation and the other configurable by means of parameter.

Two LAN output allows an easy connection between the controllers and a TTL connector for quick programming by means of an Hot Key is also available. Direct serial output **RS485 ModBUS-RTU** compatible and internal **RTC** are available as options.

3. CONTROLLING LOADS

3.1 THE SOLENOID VALVE

The regulation is performed according to the temperature measured by the thermostat probe with a positive differential from the set point: if the temperature increases and reaches set point plus differential the solenoid valve is opened and then closed when the temperature reaches the set point value again. In case of fault in the thermostat probe the opening and closing of the solenoid valve are timed through parameters "CO_n" and "CO_F".

3.2 DEFROST

Two defrost modes are available through the "tdF" parameter: defrost with electrical heater and hot gas defrost. The defrost interval is control by means of parameter "EdF": (EdF = rtc) the defrost is made in real time depending on the hours set in the parameters Ld1...Ld8 on workdays and in Sd1...Sd8 in holidays; (EdF = in) the defrost is made every "IdF" time, (EdF=Sd) the interval "IdF" is calculate through Smart Defrost algorithm (only when the SOLENOID VALVE is ON and the evaporator temperature is bigger than "SdF" parameter).

At the end of defrost the drip time is controlled through the "Fdt" parameter.

The starting of a defrost cycle can be operated locally (manual activation by means of the keyboard or digital input or end of interval time) or the command can come from the Master defrost unit of the LAN. In this case the controller will operate the defrost cycle following the parameters it has programmed but, at the end of the drip time, will wait that all the other controllers of the LAN finish their defrost cycle before to re-start the normal regulation of the temperature.

Every time any of the controller of the LAN begin a defrost cycle it issue the command into the network making all the other controllers start their own cycle. This allows a perfect synchronisation of the defrost in the whole multiplexed cabinet

3.3 CONTROL OF EVAPORATOR FANS (XM460K)

The fan control mode is selected by means of the "FnC" parameter:

- C-n** = running with the solenoid valve, OFF during the defrost;
- C-y** = running with the solenoid valve, ON during the defrost;
- O-n** = continuous mode, OFF during the defrost;
- O-y** = continuous mode, ON during the defrost;

An additional parameter "FSI" provides the setting of temperature, detected by the evaporator probe, above which the fans are always OFF. This can be used to make sure circulation of air only if his temperature is lower than set in "FSI".

4. KEYBOARDS

There are 3 kind of keyboard available for the XM440K and XM460K controller:



T640: 6 Keys, horizontal shape (185x38mm).



V640: 6 Keys, vertical shape (64x100mm).



C443: 4 Keys, horizontal shape (32x74mm).

To display and modify target set point; in programming mode it selects a parameter or confirm an operation.

set By holding it pressed for 3s when max or min temperature is displayed it will be erased.

SET By pressing it when the current time is displayed, it allows the User to re-set the current time and three holidays.

Only C443 keyboard
By holding it pressed for 5s set the instrument in Stand By

Up Arrow To see the max. stored temperature; in programming mode it browses the parameter codes or increases the displayed value.

Up Arrow By holding it pressed for 3s the give access to the "Section" menu.

Down Arrow To see the min stored temperature; in programming mode it browses the parameter codes or decreases the displayed value.

Down Arrow By holding it pressed for 3s the current time is displayed and it permits the User to enter Energy saving, Defrost and Clock parameter menu.

Only T640 and V640 keyboards
By holding it pressed for 3s the defrost is started.
By pressing it when the current time is displayed, it allows the User to set defrost times.

Light Switch ON and OFF the cold room light.

Only C443 keyboard
By holding it pressed for 3s the defrost is started.

Only T640 and V640 keyboards
Switch ON and OFF the instrument.

KEY COMBINATIONS

Up Arrow + Down Arrow To lock and unlock the keyboard.

Up Arrow + Down Arrow To enter the programming mode.

set + Up Arrow To enter the programming mode.

SET + Down Arrow To enter the programming mode.

set + Up Arrow To exit the programming mode.

SET + Down Arrow To exit the programming mode.

4.1 USE OF LEDS

Each LED function is described in the following table.

LED	MODE	Function
	ON	The SOLENOID VALVE is running
	FLASHING	- Programming Phase (flashing with LED) - Anti-short cycle delay enabled
	ON	The fan is running
	FLASHING	Programming Phase (flashing with LED)
	ON	The defrost is enabled
	FLASHING	Drip time in progress
	ON	The controller is working in "ALL" mode
	FLASHING	The controller is working in remote virtual display mode
	ON	- ALARM signal - In "Pr2" indicates that the parameter is also present in "Pr1"

4.2 HOW TO SEE THE MIN TEMPERATURE

1. Press and release the key.
2. The "Lo" message will be displayed followed by the minimum temperature recorded.
3. By pressing the key or waiting for 5s the normal display will be restored.

4.3 HOW TO SEE THE MAX TEMPERATURE

1. Press and release the key.
2. The "Hi" message will be displayed followed by the maximum temperature recorded.
3. By pressing the key or waiting for 5s the normal display will be restored.

4.4 HOW TO RESET THE MAX AND MIN TEMPERATURE RECORDED

To reset the stored temperature, when max or min temperature is displayed :

1. Press SET key until "rST" label starts blinking.

N.B. After the installation RESET the temperature stored .

4.5 HOW TO SEE AND MODIFY THE SET POINT

1. Push and immediately release the SET key: the display will show the Set point value;
2. The SET LED start blinking;
3. To change the Set value push the or arrows within 10s.
4. To memorise the new set point value push the SET key again or wait 10s.

4.6 TO START A MANUAL DEFROST

Push the DEF key for more than 2 seconds and a manual defrost will start.

Only C443 keyboard

Push the Light key for more than 3 seconds and a manual defrost will start

4.7 TO ENTER IN PARAMETERS LIST "PR1"

To enter the parameter list "Pr1" (user accessible parameters) operate as follows:

1. Enter the Programming mode by pressing the Set and DOWN key for few seconds (and start blinking).
2. The instrument will show the first parameter present in "Pr1"

4.8 TO ENTER IN PARAMETERS LIST "PR2"

To access parameters in "Pr2":

1. Enter the "Pr1" level.
 2. Select "Pr2" parameter and press the "SET" key.
 3. The "PAS" flashing message is displayed, shortly followed by "0 -" with a flashing zero.
 4. Use or to input the security code in the flashing digit; confirm the figure by pressing "SET". The security code is "321".
 5. If the security code is correct the access to "Pr2" is enabled by pressing "SET" on the last digit.
- Another possibility is the following: after switching ON the instrument the user can push Set and DOWN keys within 30 seconds.

NOTE: each parameter in "Pr2" can be removed or put into "Pr1" (user level) by pressing "SET" + . When a parameter is present in "Pr1" LED is on.

4.9 HOW TO CHANGE THE PARAMETER VALUE

1. Enter the Programming mode.
 2. Select the required parameter with or .
 3. Press the "SET" key to display its value (and LED starts blinking).
 4. Use or to change its value.
 5. Press "SET" to store the new value and move to the following parameter.
- To exit:** Press SET + UP or wait 15s without pressing a key.
- NOTE:** the new programming is stored even when the procedure is exited by waiting the time-out.

4.10 HOW TO LOCK THE KEYBOARD

1. Keep the and keys pressed together for more than 3.
2. The "POF" message will be displayed and the keyboard is locked. At this point it is only possible the viewing of the set point or the MAX o Min temperature stored and to switch ON and OFF the light, the auxiliary output and the instrument.

TO UNLOCK THE KEYBOARD

Keep the and keys pressed together for more than 3s.

4.11 ON/OFF FUNCTION KEYBOARDS T640 AND V640

By pushing the ON/OFF key, the instrument shows "OFF" for 5 sec. and the ON/OFF LED is switched ON. During the OFF status, all the relays are switched OFF and the regulations are stopped; if a monitoring system is connected, it does not record the instrument data and alarms.

N.B. During the OFF status the Light is active.

4.12 ON/OFF FUNCTION KEYBOARD C443

Keep the SET key pressed for more than 5 sec. During the OFF status, all the relays are switched OFF and the regulations are stopped; if a monitoring system is connected, it does not record the instrument data and alarms.

N.B. During the OFF status the Light is active.

4.13 TO SEE THE PROBE VALUES

1. Enter in "Pr2" level.
2. with or , select "dP1" parameter for room probe, "dP2" for evaporator probe or "dP3" for display probe.
3. Press the "SET" key to display the relative probe value.
4. Press "SET" to move to the following parameter.

5. THE SECTION MENU

This menu allows the user to access to a particular feature of the XM series related to the LAN (Local Area Network) of controllers.

A single keyboard, depending on the programming of this menu, is able to control either the module of the local section of the LAN or any of the other modules of the LAN acting as a remote virtual display. The possibilities are:

LOC: the keyboard controls and display the value, the status and the alarms of the local section of the LAN

ALL: the keyboard display the value and the status of the local section, but the command given by the keyboard are effective on all the sections of the LAN. In case of alarm the writing "ASn" is shown, where "n" is the number of the section in alarm.

SE1...Se5: the keyboard controls from remote the corresponding section (from 1 to 5 depending on LAN address) of the LAN and display the value of the probes, the whole status and all the alarms of the section. Only one of this remote control is allowed at the same time.

1. Push the key for more than 3 seconds
2. The label corresponding to the section controlled by the keyboard will be displayed.
3. With or key select the section you want to control.
4. Press "Set" key to confirm and exit

6. REAL TIME CLOCK FUNCTIONS

The following functions are available only if the Real Time Clock is present

6.1 TO SEE THE CURRENT TIME AND DAY

1. Push the key for more than 3 seconds
2. The following messages are displayed:
Hur (hour); **Min** (Minute); **dAY** (day = giorno)
3. To exit push key or wait 5 seconds

6.2 TO SET THE TIME AND THE WEEKLY HOLIDAYS

1. Push the key for more than 3 seconds
2. The current time is displayed.
3. By pushing the SET key, setting the current hour, minutes, day and the weekly holidays (up to 3) will be possible.
4. To exit, press SET + UP or wait 15s without pressing any key.

6.3 TO SET THE DEFROST TIMES



Only T640 and V640 keyboards

1. Push the **▼** key for more than 3 seconds
2. The current time is displayed.
3. By pushing DEF key, the DEF led will start flashing and setting defrost time will be possible.
4. To exit, press **SET + UP** or wait 15s without pressing any key.

7. PARAMETER LIST

REGULATION

- Hy Differential:** (0,1+25,5°C; 1+45°F): Intervention differential for set point, always positive. Solenoid valve Cut IN is Set Point Plus Differential (Hy). Solenoid valve Cut OUT is when the temperature reaches the set point.
- LS Minimum set point limit:** (-50,0°C+SET; -58°F+SET) Sets the minimum acceptable value for the set point.
- US Maximum set point limit:** (SET+110°C; SET+230°F) Set the maximum acceptable value for set point.
- OdS Outputs activation delay at start up:** (0+255 min) This function is enabled at the initial start up of the instrument and inhibits any output activation for the period of time set in the parameter. (AUX and Light can work)
- AC Anti-short cycle delay:** (0+30 min) interval between the solenoid valve stop and the following restart.
- Con solenoid valve ON time with faulty probe:** (0+255 min) time during which the solenoid valve is active in case of faulty thermostat probe. With CON=0 solenoid valve is always OFF.
- COF solenoid valve OFF time with faulty probe:** (0+255 min) time during which the solenoid valve is off in case of faulty thermostat probe. With COF=0 solenoid valve is always active.

DISPLAY

- CF Temperature measurement unit:** °C = Celsius; °F = Fahrenheit . When the measurement unit is changed the SET point and the values of the regulation parameters have to be modified
- rES Resolution (for °C):** (in = 1°C; de = 0,1°C) allows decimal point display.
de = 0,1°C; in = 1 °C
- Lod Local display :** select which probe is displayed by the remote display (**T850**)
P1 = Thermostat probe
P2 = Evaporator probe
P3 = auxiliary probe
1r2 = difference between P1 and P2 (P1-P2)

DEFROST

- tdF Defrost type:**
rE = electrical heater (SOLENOID VALVE OFF)
in = hot gas (SOLENOID VALVE and defrost relays ON)
- EdF Defrost mode:**
rtc = Real Time Clock mode. Defrost time follows Ld1+Ld8 parameters on workdays and Sd1+Sd8 on holidays.
in = interval mode. The defrost starts when the time "Idf" is expired.
Sd = Smart Defrost mode. The time IdF (interval between defrosts) is increased only when the solenoid valve is active (even non consecutively) and only if the evaporator temperature is less than the value in "SdF" (set point for SMARTFROST).
- SdF Set point for SMARTFROST:** (-30+30 °C/ -22-86 °F) evaporator temperature which allows the IdF counting (interval between defrosts) in SMARTFROST mode.
- dTE Defrost termination temperature:** (-50,0+110,0°C; -58+230°F) (Enabled only when the evaporator probe is present) sets the temperature measured by the evaporator probe which causes the end of defrost.
- IdF Interval between defrosts:** (1+120h) Determines the time interval between the beginning of two defrost cycles.
- MdF (Maximum) duration of defrost:** (0+255 min) When P2P = n, no evaporator probe, it sets the defrost duration, when P2P = y, defrost end based on temperature, it sets the maximum length for defrost.
- dFd Display during defrost:**
rt = real temperature;
it = temperature reading at the defrost start;
Set = set point;
dEF = "dEF" label;
dEG = "dEG" label;
- dAd Defrost display time out:** (0+255 min) Sets the maximum time between the end of defrost and the restarting of the real room temperature display.
- Fdt Drain down time:** (0+60 min.) time interval between reaching defrost termination temperature and the restoring of the control's normal operation. This time allows the evaporator to eliminate water drops that might have formed due to defrost.
- dPO First defrost after start-up:**
y = Immediately; n = after the IdF time

FANS (XM460K)

- FnC Fan operating mode:**
C-n = running with the solenoid valve, OFF during the defrost;
C-y = running with the solenoid valve, ON during the defrost;
O-n = continuous mode, OFF during the defrost;
O-y = continuous mode, ON during the defrost;
- Fnd Fan delay after defrost:** (0+255 min) The time interval between the defrost end and evaporator fans start.
- Fst Fan stop temperature:** (-50+110°C; -58+230°F) setting of temperature, detected by evaporator probe, above which the fan is always OFF.

ALARMS

- ALC Temperature alarm configuration**
rE = High and Low alarms related to Set Point
Ab = High and low alarms related to the absolute temperature.
- ALU High temperature alarm setting:**
ALC= rE, 0 + 50°C or 90°F
ALC= Ab, ALL + 110°C or 230°F
when this temperature is reached and after the ALd delay time the HA alarm is enabled.

ALL Low temperature alarm setting:

ALC = rE , 0 + 50 °C or 90°F

ALC = Ab , - 50°C or -58°F + ALU

when this temperature is reached and after the ALd delay time, the LA alarm is enabled.

AFH Temperature alarm and fan differential: (0,1+25,5°C; 1+45°F) Intervention differential for temperature alarm set point and fan regulation set point, always positive.

ALd Temperature alarm delay: (0+255 min) time interval between the detection of an alarm condition and the corresponding alarm signalling.

dAO Delay of temperature alarm at start-up: (0min+23h 50min) time interval between the detection of the temperature alarm condition after the instrument power on and the alarm signalling.

EdA Alarm delay at the end of defrost: (0+255 min) Time interval between the detection of the temperature alarm condition at the end of defrost and the alarm signalling.

tbA Buzzer and alarm relay silencing: by pushing one of the keypad buttons.

n= Only the Buzzer is silenced;

y= Buzzer and relay are silenced.

PROBE INPUTS

Ot Thermostat probe calibration: (-12,0+12,0°C/ -21+21°F) allows to adjust possible offset of the thermostat probe.

OE Evaporator probe calibration: (-12,0+12,0°C/ -21+21°F) allows to adjust possible offsets of the evaporator probe.

O3 Auxiliary probe calibration: (-12,0+12,0°C/ -21+21°F) allows to adjust possible offsets of the evaporator probe.

P2P Evaporator probe presence:

n= not present: the defrost stops only by time; y= present: the defrost stops by temperature and time.

P3P Auxiliary probe presence: n= not present; y= present.

HES Temperature increase during the Energy Saving cycle : (-30+30°C / -54+54°F) sets the increasing value of the set point during the Energy Saving cycle.

DIGITAL INPUTS

I1P Energy saving digital input polarity:

CL : the digital input is activated by closing the contact;

OP : the digital input is activated by opening the contact.

I2P Configurable digital input polarity:

CL : the digital input is activated by closing the contact;

OP : the digital input is activated by opening the contact

I2F Digital input operating mode: configure the digital input function:

EAL = generic alarm;

bAL = serious alarm mode;

dFr = Start defrost;

AUS = Relay AUX actuation;

onF = remote On/OFF.

Hdf = Holiday function.

did Time interval/delay for digital input alarm:(0+255 min.) Time interval to calculate the number of the pressure switch activation when I2F=PAL. If I2F=EAL or bAL (external alarms), "did" parameter defines the time delay between the detection and the successive signalling of the alarm.

bbC Type of keyboard: (4bb+8bb min.) State the kind of keyboard used: 4bb=4 keys, 6bb= 6 keys, 8bb= 8 keys

TO SET CURRENT TIME AND WEEKLY HOLIDAYS

CbP Clock board present (y = n) Presence of the RTC

Hur Current hour (0 + 23 h)

Min Current minute (0 + 59min)

dAY Current day (Sun + SAT)

Hd1 First weekly holiday (Sun + nu) Set the first day of the week which follows the holiday times.

Hd2 Second weekly holiday (Sun + nu) Set the second day of the week which follows the holiday times.

Hd3 Third weekly holiday (Sun + nu) Set the third day of the week which follows the holiday times.

N.B. Hd1,Hd2,Hd3 can be set also as "nu" value (Not Used).

TO SET DEFROST TIMES

Ld1=Ld8 Workday defrost start (0 + 23h 50 min.) These parameters set the beginning of the eight programmable defrost cycles during workdays. Ex. When Ld2 = 12.4 the second defrost starts at 12.40 during workdays.

Sd1=Sd8 Holiday defrost start (0 + 23h 50 min.) These parameters set the beginning of the eight programmable defrost cycles on holidays. Ex. When Sd2 = 3.4 the second defrost starts at 3.40 on holidays.

N.B. : To disable a defrost cycle set it to "nu"(not used).

Ex. If Ld6=nu ; the sixth defrost cycle is disabled

L.A.N. CONFIGURATION

LSn L.A.N. section number (1 + 5) States the number of sections available in the L.A.N.

Lan L.A.N. serial address (1 + LSn) Identifies the instrument address inside local network of multiplexed cabinet controller.

LSP L.A.N. set-point synchronisation

y= the section set-point, when modified, is updated to the same value on all the other sections

n= the set-point value is modified only in the local section

LdS L.A.N. display synchronisation

y= the value displayed by the section is sent to all the other sections

n= the set-point value is modified only in the local section

LOF L.A.N. On/Off synchronisation this parameter states if the On/Off command of the section will act on all the other ones too.

y= the On/Off command is sent to all the other sections

n= the On/Off command acts only in the local section

LLI L.A.N. light synchronisation this parameter states if the light command of the section will act on all the other ones too.

y= the light command is sent to all the other sections

n= the light command acts only in the local section

LAU L.A.N. AUX output synchronisation this parameter states if the AUX command of the section will act on all the other ones too.
y= the light command is sent to all the other sections
n= the light command acts only in the local section

LES L.A.N. energy saving synchronisation this parameter states if the energy saving command of the section will act on all the other ones too.
y= the Energy Saving command is sent to all the other sections.
n= the Energy Saving command acts only in the local section

Lsd Remote probe display this parameter states if the section has to display the local probe value or the value coming from another section.
y= the displayed value is the one coming from another section (which has parameter LdS = y).
n= the displayed value is the local probe one.

OTHER

Adr RS485 serial address (1÷247): Identifies the instrument address when connected to a ModBUS compatible monitoring system.

dP1 Probe 1 value displaying shows the value measured by probe 1

dP2 Probe 2 value displaying shows the value measured by probe 2

dP3 Probe 3 value displaying shows the value measured by probe 3

Rel Release software: (read only) Software version of the microprocessor.

Ptb Parameter table: (read only) it shows the original code of the **dixell** parameter map.

Pr2 Access to the protected parameter list (read only).

8. DIGITAL INPUTS

The XM series can support up to 2 free of voltage contact digital inputs. One is always configured as energy saving while the second is programmable in six different configurations by the "I2F" parameter.

8.1 ENERGY SAVING INPUT

The Energy Saving function allows to change the set point value as the result of the SET+ HES (parameter) sum. This function is enabled until the digital input is activated.

8.2 CONFIGURABLE INPUT - GENERIC ALARM (EAL)

As soon as the digital input is activated the unit will wait for "did" time delay before signalling the "EAL" alarm message. The outputs status don't change. The alarm stops just after the digital input is deactivated.

8.3 CONFIGURABLE INPUT - SERIOUS ALARM MODE (BAL)

When the digital input is activated, the unit will wait for "did" delay before signalling the "BAL" alarm message. The relay outputs are switched OFF. The alarm will stop as soon as the digital input is deactivated.

8.4 CONFIGURABLE INPUT - START DEFROST (DFR)

It executes a defrost if there are the right conditions. After the defrost is finished, the normal regulation will restart only if the digital input is disabled otherwise the instrument will wait until the "Mdf" safety time is expired.

8.5 CONFIGURABLE INPUT - RELAY AUX ACTUATION (AUS)

This function allows to turn ON and OFF the auxiliary relay by using the digital input as external switch.

8.6 CONFIGURABLE INPUT - REMOTE ON/OFF (ONF)

This function allows to switch ON and OFF the instrument.

8.7 CONFIGURABLE INPUT - HOLIDAY FUNCTION (HDF)

In Holiday function Energy saving and defrost cycles follow holiday times. (Sd1...Sd8)

8.8 DIGITAL INPUTS POLARITY

The digital inputs polarity depends on "I1P" and "I2P" parameters.
CL : the digital input is activated by closing the contact.
OP : the digital input is activated by opening the contact

9. INSTALLATION AND MOUNTING

Power modules **XM440K** and **XM460k** shall be mounted in a panel with two or more screws and they must be connected to the keyboards by means of a two-wire cable (Ø 1mm). The temperature range allowed for correct operation is 0 - 60 °C. Avoid places subject to strong vibrations, corrosive gases, excessive dirt or humidity. The same recommendations apply to probes. Let the air circulate by the cooling holes.

9.1 T640 - CUT OUT

T640 keyboard shall be mounted on vertical panel, in a 150x31 mm hole, and fixed using two screws Ø 3 x 2mm. To obtain an IP65 protection grade use the front panel rubber gasket (mod. RG-L).

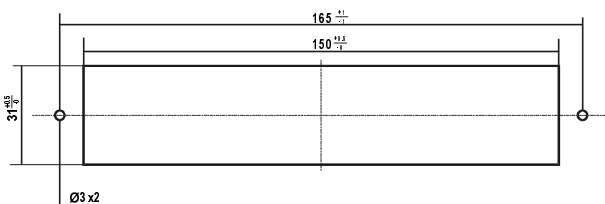

9.2 T640 MOUNTING WITH KEYBOARD COVER OPENING DOWNWARD

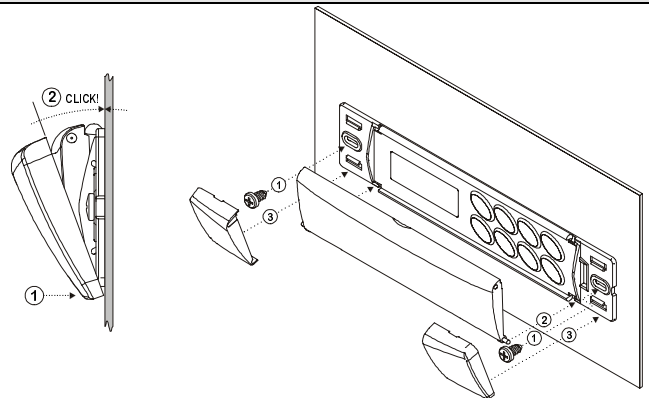

9.3 T640 MOUNTING WITH KEYBOARD COVER OPENING UPWARD

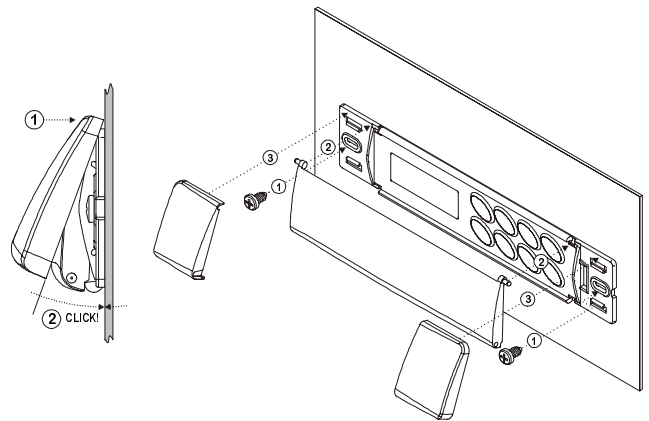

9.4 V640 - CUT OUT

V640 keyboard shall be mounted on vertical panel, in a 72x56 mm hole, and fixed using screws Ø 3 x 2mm. To obtain an IP65 protection grade use the front panel rubber gasket (mod. RGW-V).

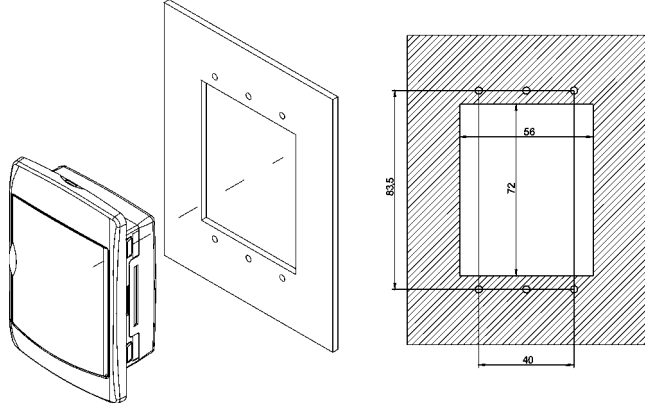

9.5 C443 - CUT OUT

C443 keyboard shall be mounted on vertical panel, in a 29x71 mm hole, and fixed using the special brackets supplied

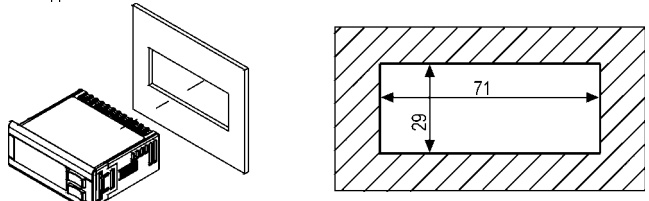

10. ELECTRICAL CONNECTIONS

The controller of XM series are provided with screw terminal block to connect cables with a cross section up to 2,5 mm² for the connection of RS485(optional), the LAN, the probes, the digital inputs and the keyboard. Other inputs, power supply and relays connections are provided with Faston connection (6,3mm). Heat-resistant cables have to be used. Before connecting cables make sure the power supply complies with the instrument's requirements. Separate the probe cables from the power supply cables, from the outputs and the power connections. Do not exceed the maximum current allowed on each relay, in case of heavier loads use a suitable external relay.

10.1 PROBE CONNECTIONS

The probes shall be mounted with the bulb upwards to prevent damages due to casual liquid infiltration. It is recommended to place the thermostat probe away from air streams to correctly measure the average room temperature. Place the defrost termination probe among the evaporator fins in the coldest place, where most ice is formed, far from heaters or from the warmest place during defrost, to prevent premature defrost termination.

11. RS485 SERIAL LINE

XM440K and XM460K are provided (on request) of a direct RS485 connection that allow the unit, to be linked to a network line ModBUS-RTU compatible as the **dixell** monitoring system XJ500 (Version 3.3).

The same TTL connector is used to upload and download the parameter list of the "HOT KEY". The instruments can be ordered with the serial output RS485(Optional).

12. USE OF THE PROGRAMMING "HOT KEY"

The XM units can UPLOAD or DOWNLOAD the parameter list from its own E2 internal memory to the "Hot Key" and vice-versa through a TTL connector.

12.1 DOWNLOAD (FROM THE "HOT KEY" TO THE INSTRUMENT)

1. Turn OFF the instrument by means of the ON/OFF key, insert the "Hot Key" and then turn the unit ON.
2. Automatically the parameter list of the "Hot Key" is downloaded into the controller memory, the "DoL" message is blinking. After 10 seconds the instrument will restart working with the new parameters.

At the end of the data transfer phase the instrument displays the following messages:

- "end" for right programming. The instrument starts regularly with the new programming.
- "err" for failed programming. In this case turn the unit off and then on if you want to restart the download again or remove the "Hot key" to abort the operation.

12.2 UPLOAD (FROM THE INSTRUMENT TO THE "HOT KEY")

1. When the XM unit is ON, insert the "Hot key" and push \leftarrow key; the "uPL" message appears.
2. The UPLoad begins; the "uPL" message is blinking.
3. Remove the "Hot Key".

At the end of the data transfer phase the instrument displays the following messages:

- "end" for right programming.
- "err" for failed programming. In this case push "SET" key if you want to restart the programming again or remove the not programmed "Hot key".

13. ALARM SIGNALS

The alarm signals displayed by the keyboard are divided into 2 groups:

1. the local alarms, which involves all the alarm related to the section directly controlled by the keyboard
 2. Remote alarms, which involves the alarms related to LAN
- The alarm message is displayed until the alarm condition is recovery. All the alarm messages are showed alternating with the room temperature except for the "P1" which is flashing. To reset the "EE" alarm and restart the normal functioning press any key, the "rSt" message is displayed for about 3s.

13.1 LOCAL ALARMS

Message	Cause	Outputs
"P1"	Thermostat probe failure	Alarm output ON; SOLENOID VALVE output according to "COOn" and "COF"
"P2"	Evaporator probe failure	Alarm output ON; Other outputs unchanged
"P3"	Auxiliary probe failure	Alarm output ON; Other outputs unchanged
"HA"	Maximum temperature alarm	Alarm output ON; Other outputs unchanged
"LA"	Minimum temperature alarm	Alarm output ON; Other outputs unchanged
"EE"	Data or memory failure	Alarm output ON; Other outputs unchanged
"EAL"	External alarm	Alarm output ON; Other outputs unchanged
"BAL"	Serious external alarm	Alarm output ON; Other outputs OFF
"rtc"	Real time clock alarm	Alarm output ON; Other outputs unchanged; Defrosts according to par. "IdF"
"rtF"	Real time clock failure alarm	Alarm output ON; Other outputs unchanged; Defrosts according to par. "IdF"

13.2 REMOTE ALARMS

Message	Cause
"ASn"	Section n is in alarm with n = LAN address of the section (parameter "Lan"). This alarm happen when the keyboard is set at "ALL". This is a generic signal that the section is alarm, to get detailed information about it set the keyboard to control that section.
"nLn"	No link alarm section n with n = LAN address of the section (parameter "Lan")
"nLn"	No link alarm when displaying a remote probe. This alarm appears when the keyboard is displaying a remote probe (parameter LdS = y)
"rdE"	Remote virtual display error. More than one keyboards are set to control remote sections

13.3 SILENCING BUZZER / ALARM RELAY OUTPUT

If "tbA = y", once the alarm signal is detected the buzzer and the relay are silenced by pressing any key. If "tbA = n", only the buzzer is silenced while the alarm relay is on until the alarm condition recovers. Buzzer is mounted in the T640 and V640 keyboards and it's an option.

13.4 "EE" ALARM

The **dixell** instruments are provided with an internal check for the data integrity. Alarm "EE" flashes when a failure in the memory data occurs. In such cases the alarm output is enabled.

13.5 ALARM RECOVERY

Probe alarms: "P1" (probe1 faulty), "P2" and "P3"; they automatically stop 10s after the probe restarts normal operation. Check connections before replacing the probe. Temperature alarms "HA" and "LA" automatically stop as soon as the thermostat temperature returns to normal values or when the defrost starts. External alarms "EAL", "BAL" stop as soon as the external digital input is disabled. No link alarms "nLn" and "nLn" automatically stop after the connection with the section is restored. "RdE" alarm automatically stop when only one keyboard is set as remote virtual display again

14. TECHNICAL DATA

V640 and T640 keyboards

Housing: self extinguishing ABS.
Case: facia 38x185 mm; depth 23mm
Mounting:
 panel mounting in a 150x31 mm panel cut-out with two screws. \varnothing 3 x 2mm.
 Distance between the holes 165mm
Protection: IP20.
Frontal protection: IP65 with frontal gasket mod RG-L. (optional)
Connections: Screw terminal block \leq 2,5 mm² heat-resistant wiring
Power supply: from power module
Display: 3 digits, red LED, 14,2 mm high.
Optional output: buzzer

C443 keyboards

Housing: self extinguishing ABS.
Case: facia 32x74 mm; depth 23mm
Mounting: panel mounting in a 71x29 mm panel cut-out.
Frontal protection: IP65
Connections: Screw terminal block \leq 2,5 mm² heat-resistant wiring
Power supply: from power module
Display: 3 digits, red LED, 14,2 mm high.
Optional output: buzzer

Power modules XM440K & XM460K

Case:
 "OS": open board 132x 94 mm; height: 40mm.
 "GS": case 155x114; height 70mm. Self extinguishing ABS. IP55
Connections: Screw terminal block \leq 2,5 mm² heat-resistant wiring and 6,3mm Faston
Power supply: 230V \varnothing or. 110V \varnothing \pm 10%
Power absorption: 10VA max.
Inputs: 3 NTC probes
Digital inputs: 2 free voltage
Solenoid Valve: relay SPST 8(3) A, 250Vac
Light: relay SPST 16(6) A, 250Vac
fans: relay SPST 8(3) A, 250V \varnothing
defrost: relay SPST 20(8) A, 250V \varnothing
Serial output: RS485 optional
Communication protocol: ModBUS - RTU
Data storing: on the non-volatile memory (EEPROM).
Internal clock back-up: 24 hours
Kind of action: 1B.
Pollution grade: normal
Software class: A.
Operating temperature: 0+60 °C.
Storage temperature: -25+60 °C.
Relative humidity: 20+85% (no condensing)
Measuring and regulation range:
NTC probe: -40+110°C (-58+230°F)
Resolution: 0,1 °C or 1 °C or 1 °F (selectable).
Accuracy (ambient temp. 25°C): \pm 0,5 °C \pm 1 digit

15. CONNECTIONS

15.1 XM440K

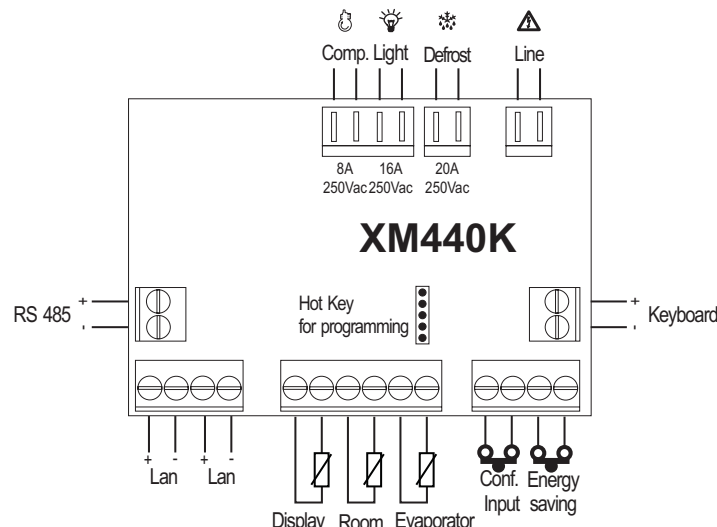

15.2 XM460K

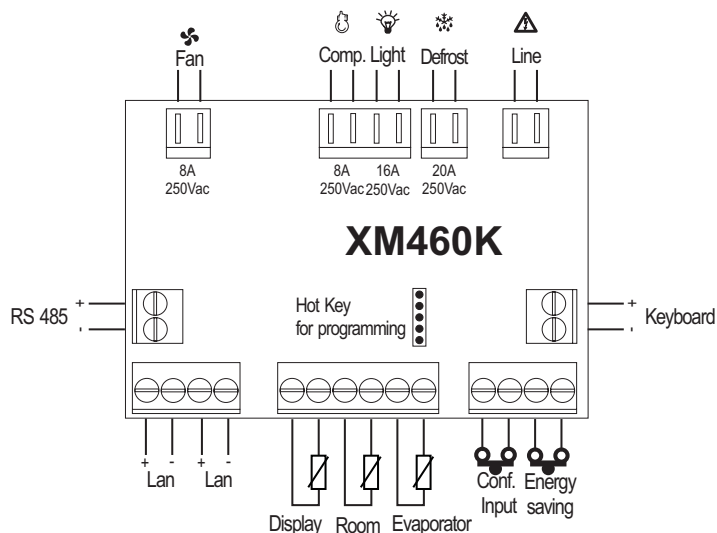

16. DEFAULT SETTING VALUES

Label	Name	Range	Default	XM440	XM460
REGULATION					
Set	Set point	LS+US	-5/23	Pr1	Pr1
Hy	Differential	0,1+25,5 °C / 1+45°F	2/4	Pr1	Pr1
LS	Minimum set point	-50,0°C+SET / -58°F+SET	-30/-22	Pr2	Pr2
US	Maximum set point	SET + 110°C / SET + 230°F	20/68	Pr2	Pr2
OdS	Outputs activation delay at start up	0+255 min.	1	Pr2	Pr2
AC	Anti-short cycle delay	0+30 min.	1	Pr1	Pr1
COOn	solenoid valve on time with faulty probe	0+255 min.	15	Pr2	Pr2
COF	solenoid valve off time with faulty probe	0+255 min.	30	Pr2	Pr2
DISPLAY					
CF	Temperature measurement unit	°C + °F	°C/°F	Pr2	Pr2
rES	Resolution (integer/decimal point)	in + de	de	Pr1	Pr1
Lod	Local display	P1 + P2 + P3 + 1r2	P1	Pr2	Pr2
DEFROST					
IdF	Defrost type	rE, in	rE	Pr1	Pr1
EdF	Defrost mode	rtc, In, Sd	In	Pr2	Pr2
SdF	Set point for SMART DEFROST	-30 + +30°C / -22 + +86°F	0	Pr2	Pr2
dTE	Defrost termination temperature (1°Evaporator)	-50,0+110°C / -58+230°F	8/46	Pr1	Pr1
IdF	Interval between defrost cycles	1+120h	6	Pr1	Pr1
MdF	(Maximum) length for 1° defrost	0+255 min.	30	Pr1	Pr1
dFd	Displaying during defrost	rt, it, SEI, dEF, dEG	it	Pr2	Pr2
dAd	MAX display delay after defrost	0+255 min.	30	Pr2	Pr2
Fdt	Draining time	0+60 min.	0	Pr2	Pr2
dPO	First defrost after start up	n + y	n	Pr2	Pr2
FANS					
FnC	Fans operating mode	C-n, C-y, O-n, O-y	O-n	N.A.	Pr2
Fnd	Fans delay after defrost	0+255 min.	10	N.A.	Pr2
FSt	Fans stop temperature	-50,0+110°C / -58+230°F	2/35	N.A.	Pr2
ALARMS					
ALC	Temperature alarms configuration	rE+Ab	rE	Pr2	Pr2
ALU	MAXIMUM temperature alarm	-50,0+110°C/-58+230°F	10/20	Pr1	Pr1
ALL	minimum temperature alarm	-50,0+110°C/-58+230°F	10/20	Pr1	Pr1
AFH	Temperature alarm and fan differential	0,1+25,5 °C / 1+45°F	2/4		
ALd	Temperature alarm delay	0+255 min.	15	Pr2	Pr2
dAO	Delay of temperature alarm at start up	0 + 23h 50 min.	1,3	Pr2	Pr2
EdA	Alarm delay at the end of defrost	0+255 min.	30	Pr2	Pr2
tBA	Alarm relay silencing	y + n	y	Pr2	Pr2
ANALOGUE INPUTS					
Ot	Thermostat probe calibration	-12,0+12,0°C / -21+21°F	0	Pr1	Pr1
OE	Evaporator probe calibration	-12,0+12,0°C / -21+21°F	0	Pr2	Pr2
O3	Auxiliary probe calibration	-12,0+12,0°C / -21+21°F	0	Pr2	Pr2
P2P	Evaporator probe presence	n + y	y	Pr2	Pr2
P3P	Auxiliary probe presence	n + y	n	Pr2	Pr2
HES	Temperature increase during the Energy Saving cycle	-30+30°C / -54+54°F	0	Pr2	Pr2
DIGITAL INPUTS					
I1P	Energy Saving switch polarity	CL+OP	CL	Pr2	Pr2
I2P	Configurable digital input polarity	CL+OP	CL	Pr2	Pr2
I2F	Digital input configuration	EAL, bAL, PAL, dFr, AUS, ES, OnF	EAL	Pr2	Pr2

Label	Name	Range	Default	XM440	XM460
dId	Digital input alarm delay	0+255 min.	5	Pr2	Pr2
bbc	Type of keyboard	4bb + 8bb	6bb	Pr2	Pr2
TIME AND WEEKLY HOLIDAYS					
CbP	Clock Board presence	n + y	n	Pr2	Pr2
Hur	Current hour	0 + 23	0	Pr2	Pr2
Min	Current minute	0 + 59	0	Pr2	Pr2
dAY	Current day	Sun + SAT	Sun	Pr2	Pr2
Hd1	First weekly holiday	Sun + SAT - nu	nu	Pr2	Pr2
Hd2	Second weekly holiday	Sun + SAT - nu	nu	Pr2	Pr2
Hd3	Third weekly holiday	Sun + SAT - nu	nu	Pr2	Pr2
ENERGY SAVING TIMES					
ILE	Energy Saving cycle start during workdays	0 + 23h 50 min.	0	Pr2	Pr2
dLE	Energy Saving cycle length during workdays	0 + 24h 00 min.	0	Pr2	Pr2
ISE	Energy Saving cycle start on holidays	0 + 23h 50 min.	0	Pr2	Pr2
dSE	Energy Saving cycle length on holidays	0 + 24h 00 min.	0	Pr2	Pr2
HES	Temperature increase during the Energy Saving cycle	-30+30°C / -54+54°F	0	Pr2	Pr2
DEFROST TIMES					
Ld1	1 st workdays defrost start	0 + 23h 50 min. - nu	6,0	Pr2	Pr2
Ld2	2 nd workdays defrost start	0 + 23h 50 min. - nu	13,0	Pr2	Pr2
Ld3	3 rd workdays defrost start	0 + 23h 50 min. - nu	21,0	Pr2	Pr2
Ld4	4 th workdays defrost start	0 + 23h 50 min. - nu	nu	Pr2	Pr2
Ld5	5 th workdays defrost start	0 + 23h 50 min. - nu	nu	Pr2	Pr2
Ld6	6 th workdays defrost start	0 + 23h 50 min. - nu	nu	Pr2	Pr2
Ld7	7 th workdays defrost start	0 + 23h 50 min. - nu	nu	Pr2	Pr2
Ld8	8 th workdays defrost start	0 + 23h 50 min. - nu	nu	Pr2	Pr2
Sd1	1 st holiday defrost start	0 + 23h 50 min. - nu	6,0	Pr2	Pr2
Sd2	2 nd holiday defrost start	0 + 23h 50 min. - nu	13,0	Pr2	Pr2
Sd3	3 rd holiday defrost start	0 + 23h 50 min. - nu	21,0	Pr2	Pr2
Sd4	4 th holiday defrost start	0 + 23h 50 min. - nu	nu	Pr2	Pr2
Sd5	5 th holiday defrost start	0 + 23h 50 min. - nu	nu	Pr2	Pr2
Sd6	6 th holiday defrost start	0 + 23h 50 min. - nu	nu	Pr2	Pr2
Sd7	7 th holiday defrost start	0 + 23h 50 min. - nu	nu	Pr2	Pr2
Sd8	8 th holiday defrost start	0 + 23h 50 min. - nu	nu	Pr2	Pr2
LAN CONFIGURATION					
LSn	L.A.N. section number	1 + 5	1	Pr2	Pr2
Lan	L.A.N. serial address	1 + LSn	1	Pr2	Pr2
LSP	L.A.N. Set-point synchronisation	n + y	n	Pr2	Pr2
Lds	L.A.N. display synchronisation	n + y	n	Pr2	Pr2
LOF	L.A.N. On/Off synchronisation	n + y	n	Pr2	Pr2
LLi	L.A.N. Light synchronisation	n + y	n	Pr2	Pr2
LAU	L.A.N. AUX output synchronisation	n + y	n	Pr2	Pr2
LES	L.A.N. Energy Saving synchronisation	n + y	n	Pr2	Pr2
LSd	Remote probe display	n + y	n	Pr2	Pr2
OTHER					
Adr	RS485 Serial address	0+247	1	Pr1	Pr1
dP1	Probe 1 value display	---	---	Pr2	Pr2
dP2	Probe 2 value display	---	---	Pr2	Pr2
dP3	Probe 3 value display	---	---	Pr2	Pr2
rEL	Software release	---	---	Pr2	Pr2
Ptb	Map code	---	---	Pr2	Pr2
Pr2	Access parameter list	---	---	Pr2	Pr2

Dixell s.r.l. Via dell'Industria, 27 - 32010 Z.I. Pieve d'Alpago (BL) ITALY
 tel. +39 - 0437 - 98 33 - fax +39 - 0437 - 98 93 13
 E-mail: dixell@dixell.com - http://www.dixell.com